

# Miniverter Mark3

*A bare-bones VHF or UHF transverter*

Paul Wade W1GHZ ©2021

**w1ghz@arri.net**

All my cheap and simple microwave transverters have a single mixer at the 144 or 432 MHz IF interface, requiring 1 milliwatt (0 dBm) or less input power for transmit. I'd like to use them with an SDR, so a transverter from HF to 144 or 432 is needed. A high-power transverter seems like overkill and unnecessary expense, so a simple transverter should be adequate.

A few years back, I built a Miniverter<sup>1</sup> – a simple transverter with a mixer, a bandpass filter, and a MMIC amplifier in each direction to provide enough gain to overcome the loss of the mixer and filter. The original version used a Toko helical filter; which became expensive, and then unavailable. A second version, the Miniverter-F<sup>2</sup>, was aimed at a Flex-1500 SDR – it had a matching DB9 interface connector. This version used a Temwell filter; they are hard to find, at least in small quantities.

Recently I built an Anglian3 transverter kit from G4DDK<sup>3</sup> to use on 2 meters in place of my old IC275 transceiver. The filters in his design use shielded coils from Coilcraft and provide very good performance. I was so pleased with the performance that I adapted the design to a 222 MHz transverter<sup>4</sup>, scaling the filters with similar Coilcraft inductors. The Coilcraft inductors are inexpensive and available from Mouser; Coilcraft seems to be a company that does not quickly obsolete components, making them a better choice for new designs.

I have had some requests for Miniverters, but have not made more PC boards since the filters are hard to find. I decided that a new version with the same three-resonator filter as the Anglian3 transverter might have a longer life. I made a new PC board layout with all surface-mount components (except the Coilcraft inductors and a relay). This version can also be built for 222 or 432 MHz, by changing the filter components, or any frequency between perhaps 50 and 450 MHz, if required. For instance, the 137 MHz weather satellite frequency could be received by simply retuning the 144 MHz coils and providing an appropriate LO frequency.

The local oscillator is always a problem for inexpensive transverters. Crystals have also become hard to find. Computer oscillators are only available for a limited number of frequencies (don't even consider the programmable ones – the output spectrum is crap). However, with an SDR, oddball IF frequencies can be used, with the software doing the offset correction, so I included a footprint for a surface-mount oscillator that should fit most package sizes. But my intent is to use a separate LO, thru an SMA connector. Inexpensive Chinese synthesizer boards should be adequate, and can be programmed for any desired frequency.

## Design

The design is pretty basic – a mixer, a good bandpass filter, an amplifier in each direction, and a relay to switch power to the amplifiers and as a TR switch. Separate transmit and receive ports are also possible, with a couple of quick cuts with an X-Acto knife. There is also a rudimentary sequencer with an output that switches to ground before the internal TR relay. The schematic is in Figure 1.

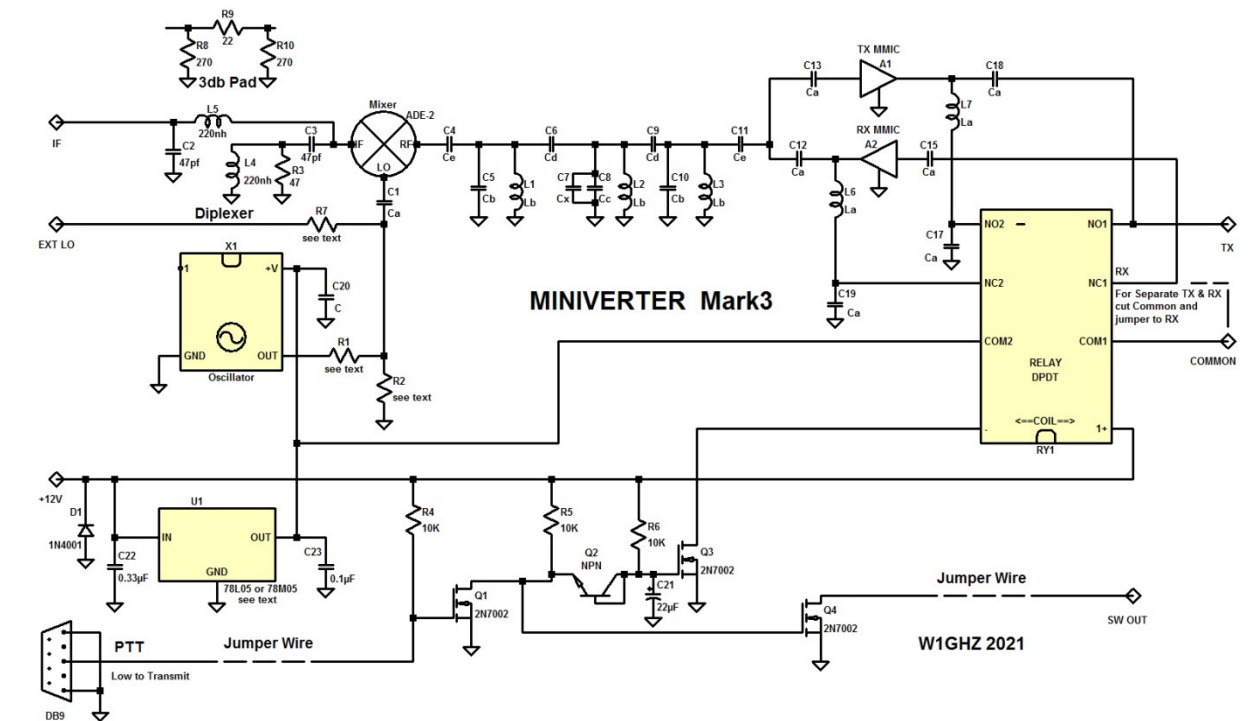
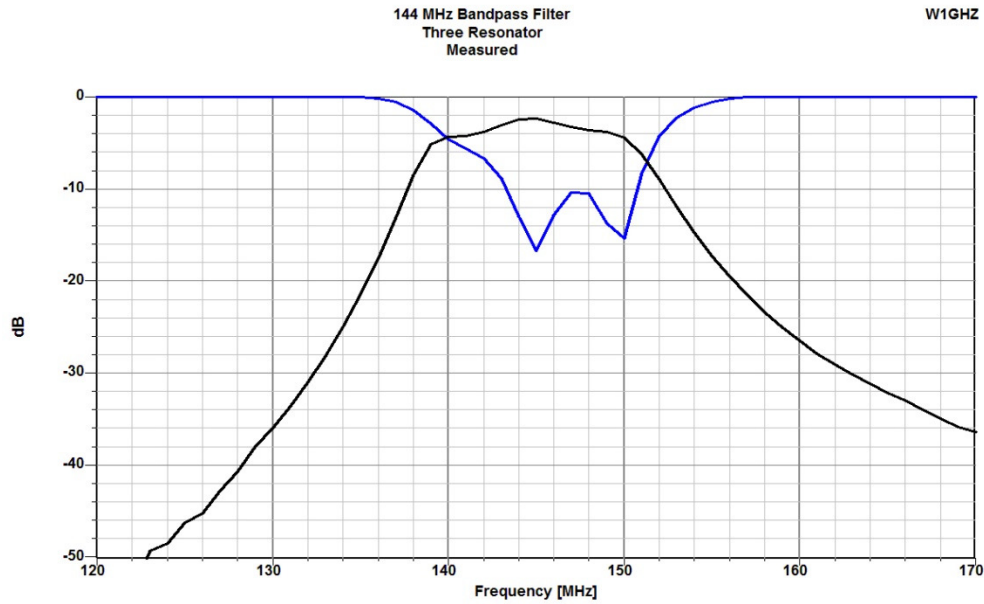

**Figure 1 – Miniverter Mark3 schematic diagram**

There are several options other than the choice of output configurations. The IF port includes a diplexer to better match the mixer, but it could be replaced with a small attenuator or just bypassed. The local oscillator can be a crystal oscillator or an external source; both choices have a resistive divider to reduce the LO level if needed (R1 & R2 for internal, R7 & R2 for external).

The major option is the choice of MMICs, which can be the old 4-lead variety or the newer SOT-89 package with ground tab. The newer ones can provide improved performance, but many of them operate at 5 volts, while the older ones use a higher voltage with a bias resistor. For 5-volt MMICs, the voltage regulator U1 should be a 5 volt regulator; footprints are available for both a 78L05 and a higher current 78M05 – the higher performance MMICs need more current. Other MMICs need a higher voltage regulator, like a 78L08 or 78M08, or can just be run from 12 volts if the source is regulated. The bias resistors replace RF chokes L6 and L7; bias resistor values for different voltages can be found on each MMIC data sheet.

Band selection is by choosing the appropriate bandpass filter, with values and Mouser part numbers shown on the parts list. The 144 MHz filter is borrowed from G4DDK, with performance measured performance shown in Figure 2 after tuning.



**Figure 2 – 144MHz Filter from G4DDK Anglian 3L Transverter**

One trick I use to make tuning easier is to put a VNA signal into the LO port, with no IF or LO signal, and measure the gain through the mixer and TX amplifier to the output. Going straight through the mixer this way is quite lossy, but the filter response can be seen directly in Figure 3 and the filter can be readily tuned.

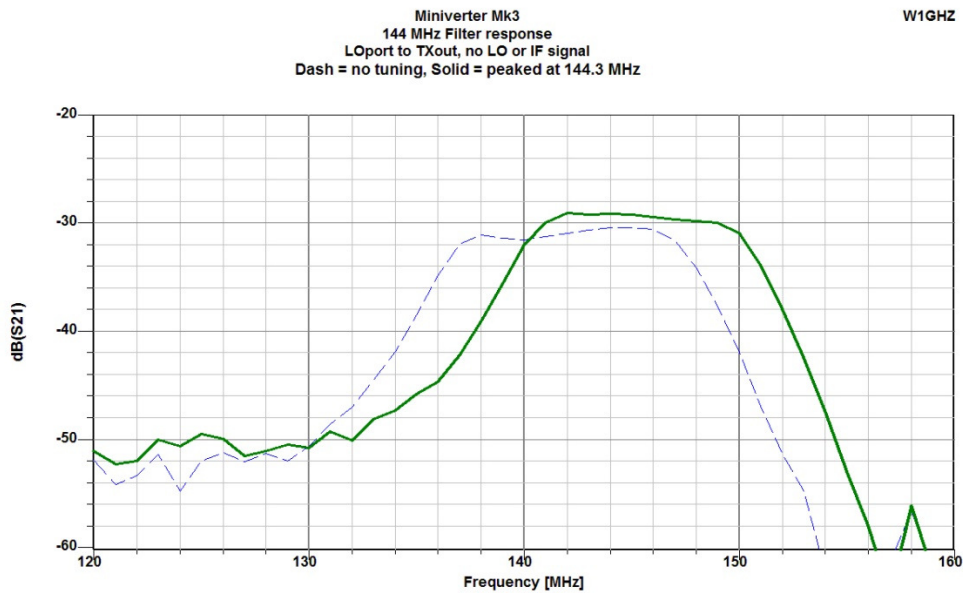

**Figure 3 – Tuning straight through mixer, before and after tuning**

The 222 MHz filter used in the 222 MHz transverter<sup>4</sup> is adapted from from the G4DDK 2-meter filter, with measured performance in Figure 4.

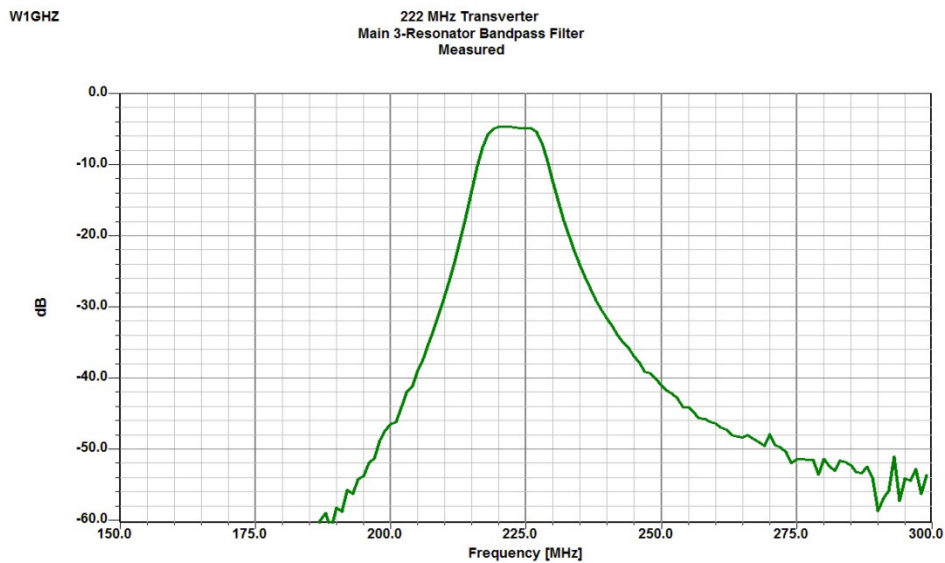

**Figure 4 – 222 MHz Filter Response**

The 432 MHz filter took a bit of fiddling to use the same size Coilcraft inductors, and ended up the performance shown in Figure 5. This one is a bit wider, so suggested tuning is with 432 MHz at the lower edge of the filter response to reduce LO leakage. The suggested tuning is easily accomplished by peaking up around 438 MHz.

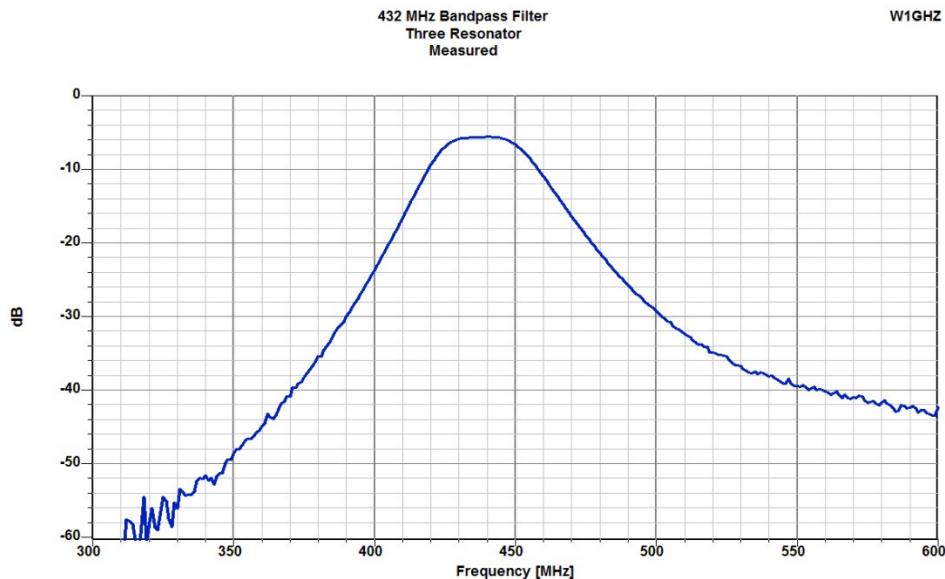
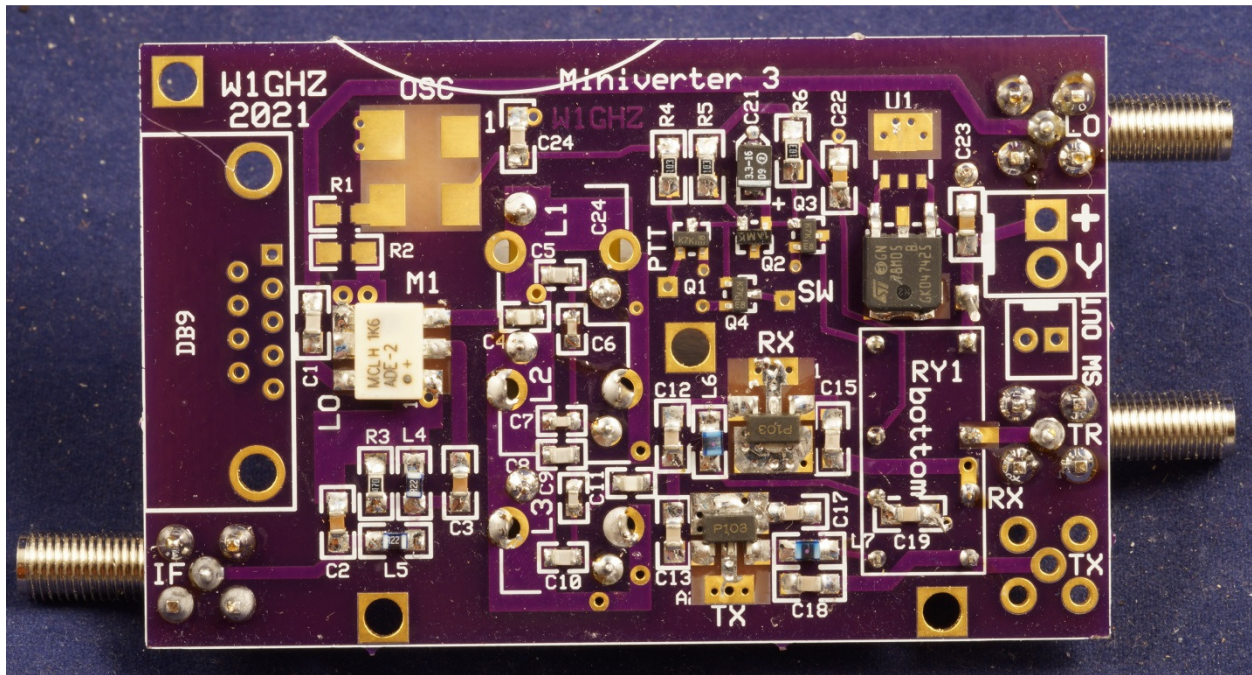

**Figure 5 – 432 MHz Filter Response after tuning**

One note on the circuit: Q2 in the sequencer is really a diode, but surface-mount diodes come in too many different packages, and transistors are cheaper. I have a reel of them so I would be glad to supply one in with a PC board.

## Construction

The transverter is a PC board with surface-mount components wherever possible. The circuitry and soldering is all on one side. I made every effort to space and identify all components for easy assembly. The surface-mount footprints will fit 0805 size components or the larger 1206 size, except the capacitors in the bandpass filter which only seem to be available in smaller package sizes. A completed transverter with external Local Oscillator and common transmit and receive is shown in Figure 6.



**Figure 6 – Component side of Miniverter Mark3**

The transverter in Figure 6 has a single TR connector for transmit and receive, with the TX port unused. With a simple cut with an X-Acto knife and the addition of one jumper wire, shown in Figure 7, separate transmit and receive connectors become available – the TR becomes the RX.

**Figure 7 – PCB modification for separate RX and TX**

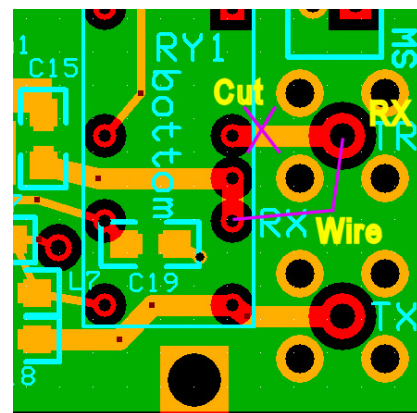



The back side of the board is a ground plane; I chose to have two jumper wires on the back rather than break up the ground plane. The wire locations are shown in silk screen on the board, as seen in Figure 8.

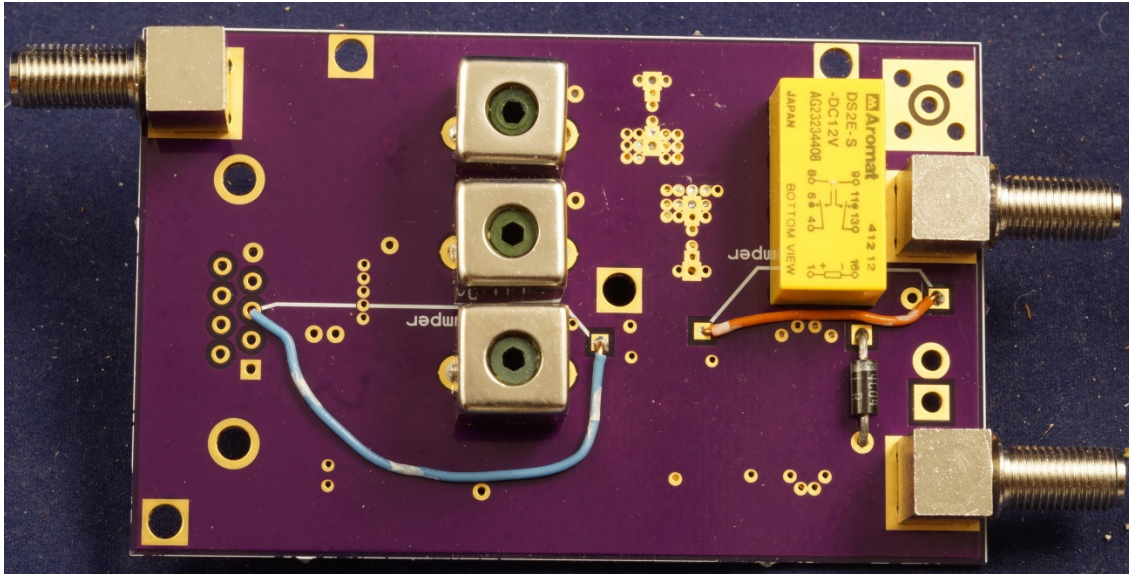

**Figure 8 – Ground plane side of Miniverter Mark3**

The inductors, relay, SMA connectors, and optional DB9 connector for a Flex-1500 mount on the backside. The only thing that is critical is the inductor orientation – slide the can off one and check the orientation before inserting them in the board, taking care to ground the indicated end as shown in the sketch, Figure 9.

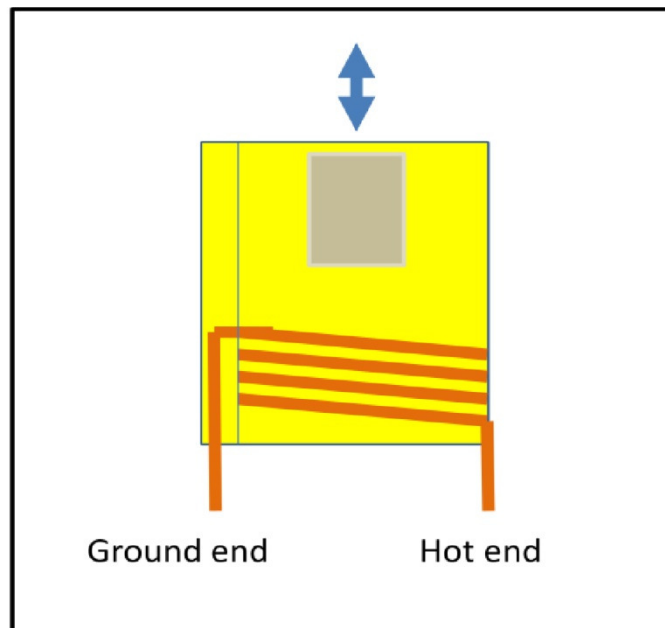

**Figure 9 – Tunable Inductor Orientation (courtesy G4DDK)**

The board size was chosen to fit in an extruded housing which holds a 50mm x 80mm PC board, shown in Figure 10, since the filters are a bit too tall for an Altoids tin. However, the housing is too short for the 222 MHz and 432 MHz inductors. If I have another batch of PC boards made, they will be for a slightly larger housing.

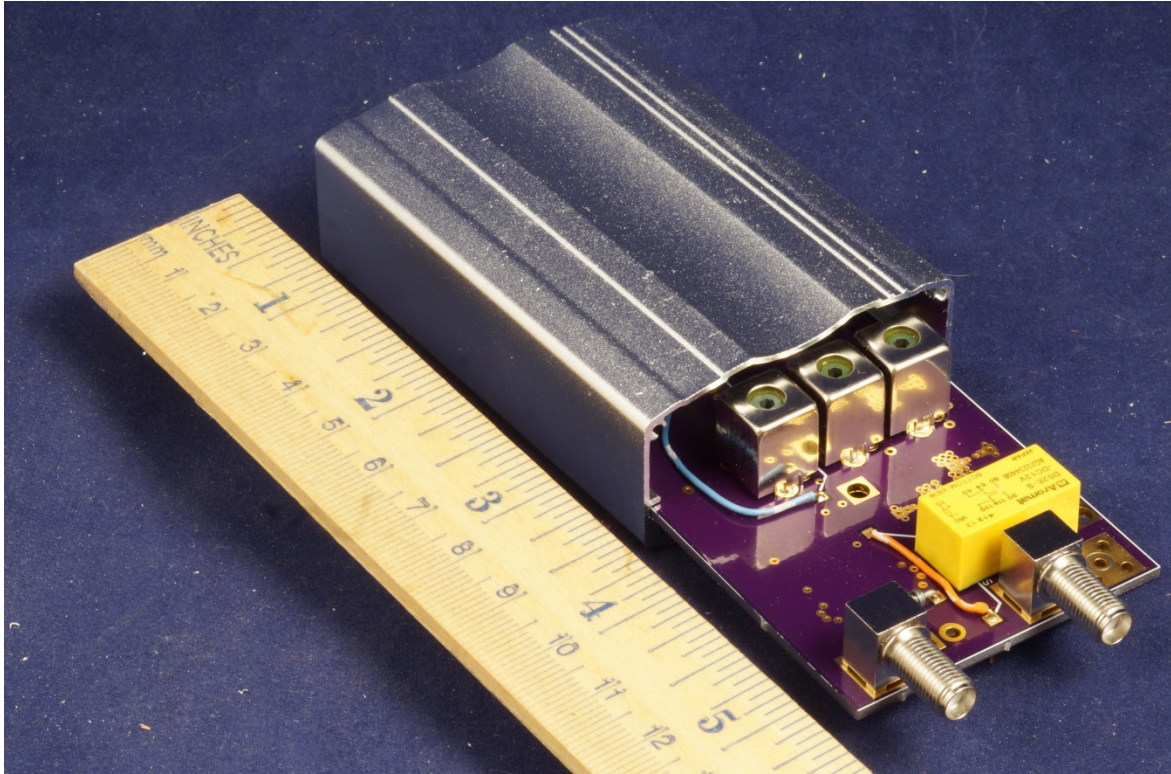

**Figure 10 – Miniverter Mark3 can be packaged in small extruded housing**

## **Tuneup**

Tuneup is pretty straight forward. Apply voltage, ground the PTT pin, and listen for a click from the relay. If the LO is external, adjust for around +7 dBm. With the PTT grounded, apply some signal to the IF port, perhaps -10 dBm. There should be some output on a power meter or spectrum analyzer; if so, tune the three inductors in the bandpass filter for maximum output. Then turn off the IF signal to check for excess LO leakage. Adjust tuning if need to reduce LO leakage without much loss of desired output.

Check the receive direction by opening the PTT, putting in a small signal, and listening for it at the IF port.

A cheap spectrum analyzer like the tinySA, or a cheap VNA like the nanoVNA, makes tuneup easier. These very inexpensive instruments will find many other uses.

## Performance

I assembled two prototypes, one for 144 MHz and one for 432. In both, I used PGA-103 MMICs to get more gain. Using such hot MMICs was probably not the best idea, since they seem to be right on the edge – putting a finger in a magic spot sets them off at ~ 1.4 GHz. Lower gain MMICs recommended.

The two-meter unit, tested with +6 dBm local oscillator at 116 MHz, has about 14 dB net gain in each direction. The 1 dB compression point on transmit is about 14 dBm. That is more than needed for most microwave transverters, so lower gain MMICs would be fine. LO leakage is around -75 dBm, and harmonics were down more than 60 dB.

The 432 MHz unit, tested with only +2 dBm local oscillator at 404 MHz, has less gain, about 4 dB in direction. LO leakage was -49 dBm, probably because the filter is a bit wider, and harmonics were at least 50 dB down.

## Summary

This is a simple, bare-bones transverter to get an SDR working with a microwave transverter. It has pretty good performance, so system performance should be better than with the older VHF multimode rigs. It has other potential uses, as a simple up or down converter to some odd frequency, for instance, or to monitor a frequency without dedicating an expensive radio. Feel free to hack up a board as needed, and let me know if you find a clever application.

PC boards are available.

## Notes

1. P. Wade, W1GHZ, “2-meter Miniverter,” *N.E.W.S. Letter*, North East Weak Signal Group, March 2001, pp. 5-6. <http://www.w1ghz.org/miniverter.zip>
2. P. Wade, W1GHZ, “Miniverter for the Flex-1500 and Microwave Transverters,” <http://www.w1ghz.org/PCBproj/Miniverter-F.pdf>
3. S. Jewell, G4DDK, “Anglian 3L 144MHz transverter,” <http://www.g4ddk.com/Anglian3Ltechdes.pdf>
4. P. Wade, W1GHZ, “222 MHz Transverter, Mark 3,” [http://www.w1ghz.org/xvtr/222\\_MHz\\_Transverter\\_Mark3.pdf](http://www.w1ghz.org/xvtr/222_MHz_Transverter_Mark3.pdf)



## Errata

I made an error in the PC board layout in the IF duplexer. It can be easily fixed with one cut and a short wire, as shown below:

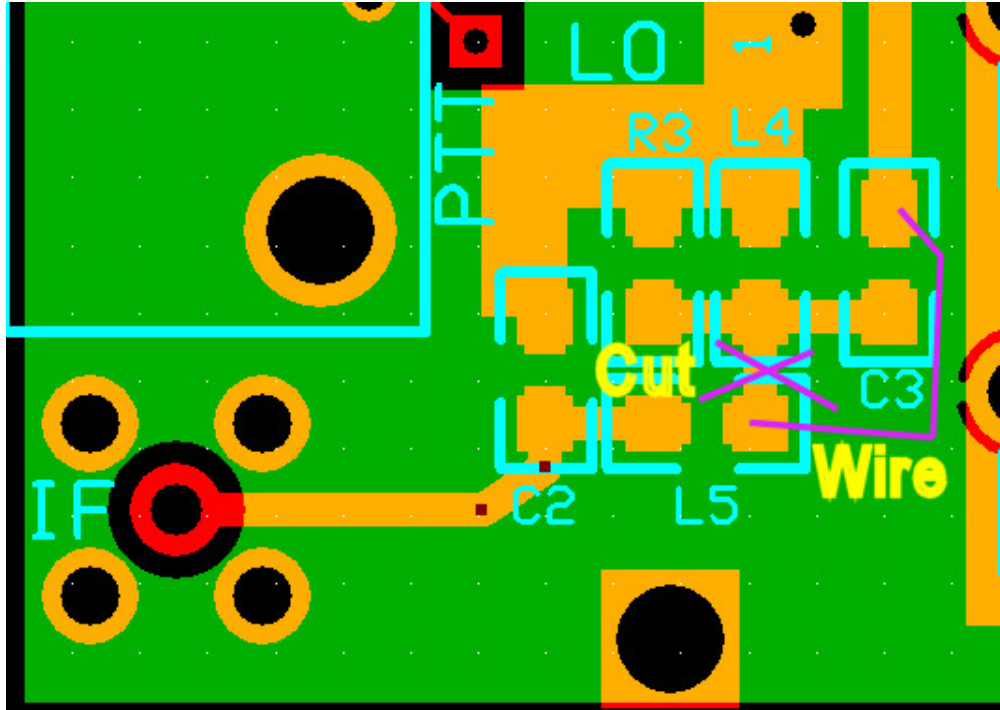

Correction to PCB for IF Diplexer