

222 MHz Transverter, Mark 3

Paul Wade W1GHZ ©2020

w1ghz@arrl.net

There isn't a lot of equipment available for 222 MHz operation, and it is great band for weak-signal work – sometimes better than 2 meters. The only currently available commercial choice is from Down East Microwave, now supplied by Q5 Signal (q5signal.com). Those just getting started on this band might prefer a simpler choice, and some hams might prefer to build their own.

I published a simple 222 MHz transverter design¹ in 2003 intended as an accessory for the Yaesu FT-817. It was moderately popular, but component obsolescence became a problem after a few years. An update² in 2017 fixed some of the problems, and the discovery of a stash of some of the critical parts by Dick Frey, WA2AAU, extended the useful life.

This 222 MHz transverter is an attempt to make a design using parts that should be available for a longer time. Another objective is to make it easier to build, at least for those who can work with surface-mount components. I have applied my years of design experience in the electronics industry, where we attempted to fit 10 pounds of stuff into a two-pound bag rather than the usual 5 pounds.

Background

I had been thinking about a 2-meter transverter to use with an SDR to replace my aging IC-275 when Sam Jewell, G4DDK, published his Anglian transverter^{3,4} in 2014. It looked like a high-performance unit, so I bought a kit. When Sam improved it⁵ to the Anglian 3L, I bought another kit, plus an extra PC board to experiment with. One possibility was to see if it could be modified for 222 MHz, a band not available in Europe. But it stayed low on the project list.

I have been using an older Down East Microwave transverter on 222 MHz for years, but the priority for a new one increased last year when it started acting up. After years of running fine at about 10 watts out, it suddenly started putting out closer to 30 watts and blew up my amplifier. I replaced the amplifier and used a long cable between them to operate the September VHF Contest. Sometime later, the output was much lower. I removed the long cable and was able to run at reduced power for the January VHF Contest, making most contacts on CW.

I revisited the Anglian 3L, but the onboard local oscillator was a problem. I didn't have a suitable crystal (I recently found that Q5Signal sells them) and it seemed like it would take some fiddling to make it work. I could hack into the board and use an external LO, but the board is quite compact without a lot of room to work with. UK hams love those little tin boxes, but they don't have much room.

I finally decided that a new design and PC board layout was in order, with a separate LO so I could use a synthesizer and lock it to GPS if needed. A good starting point was to borrow the pieces of the Anglian 3L that I liked, which turned out to be a lot of the RF circuitry. Sam and his friends did a nice job.

For the PC board layout, I decided that only the RF circuitry would be included. The LO is separate, and switching, voltage regulation, and power amplifier would also be separate. Thus, this board is the heart of a modular design.

I also avoided the mistake of choosing an enclosure or even board size. Instead, I did a PC layout of each section of the transverter, allowing adequate spacing for easy hand assembly and silkscreen component identifiers, and keeping all surface-mount components on one side. Then I folded the layout into a more compact rectangle, without cramming. I hope this makes the transverter easier to replicate. A completed transverter board is shown in Figure 1. The IF connectors are on the opposite edge of the board from the RF connectors, to minimize coupling.

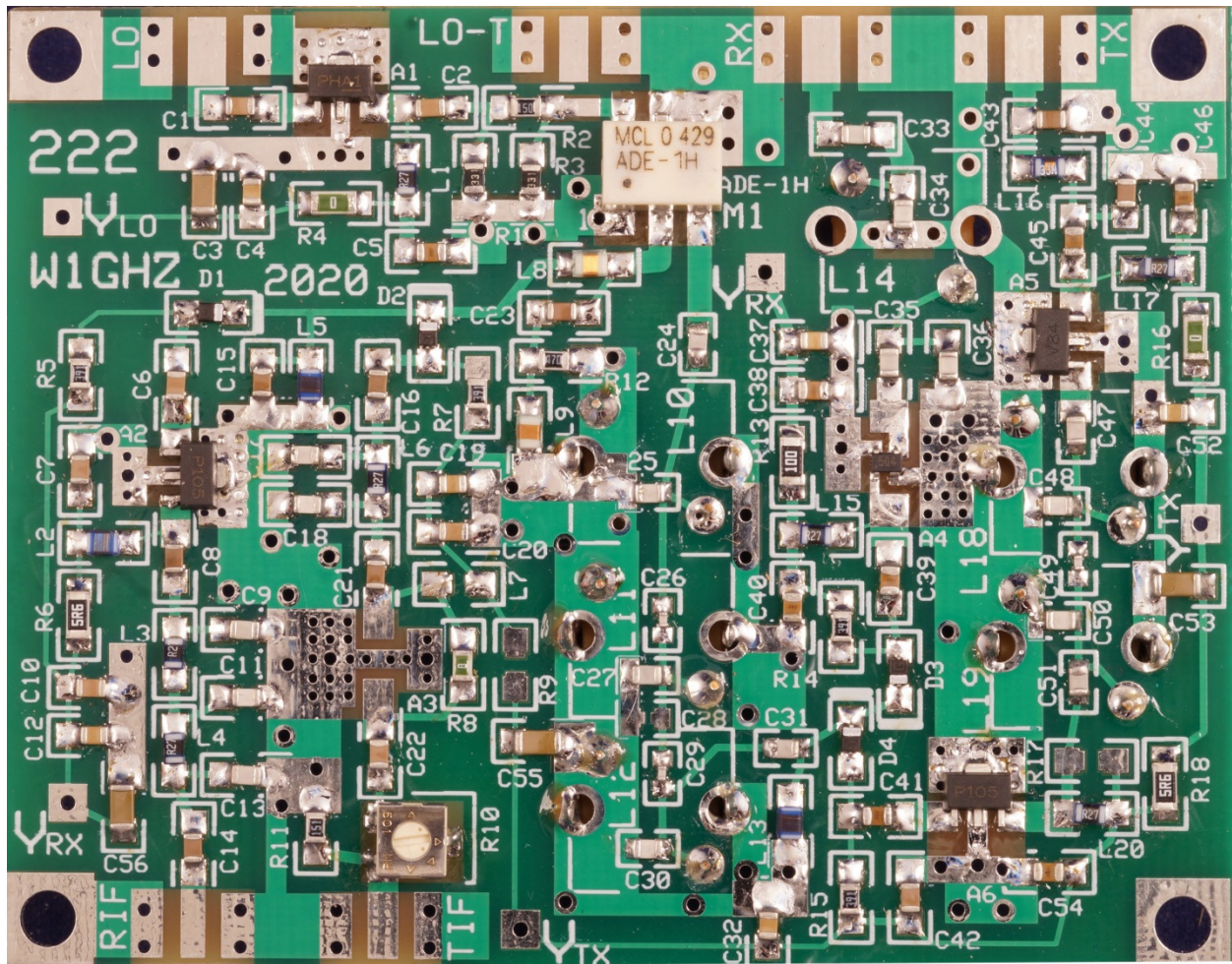
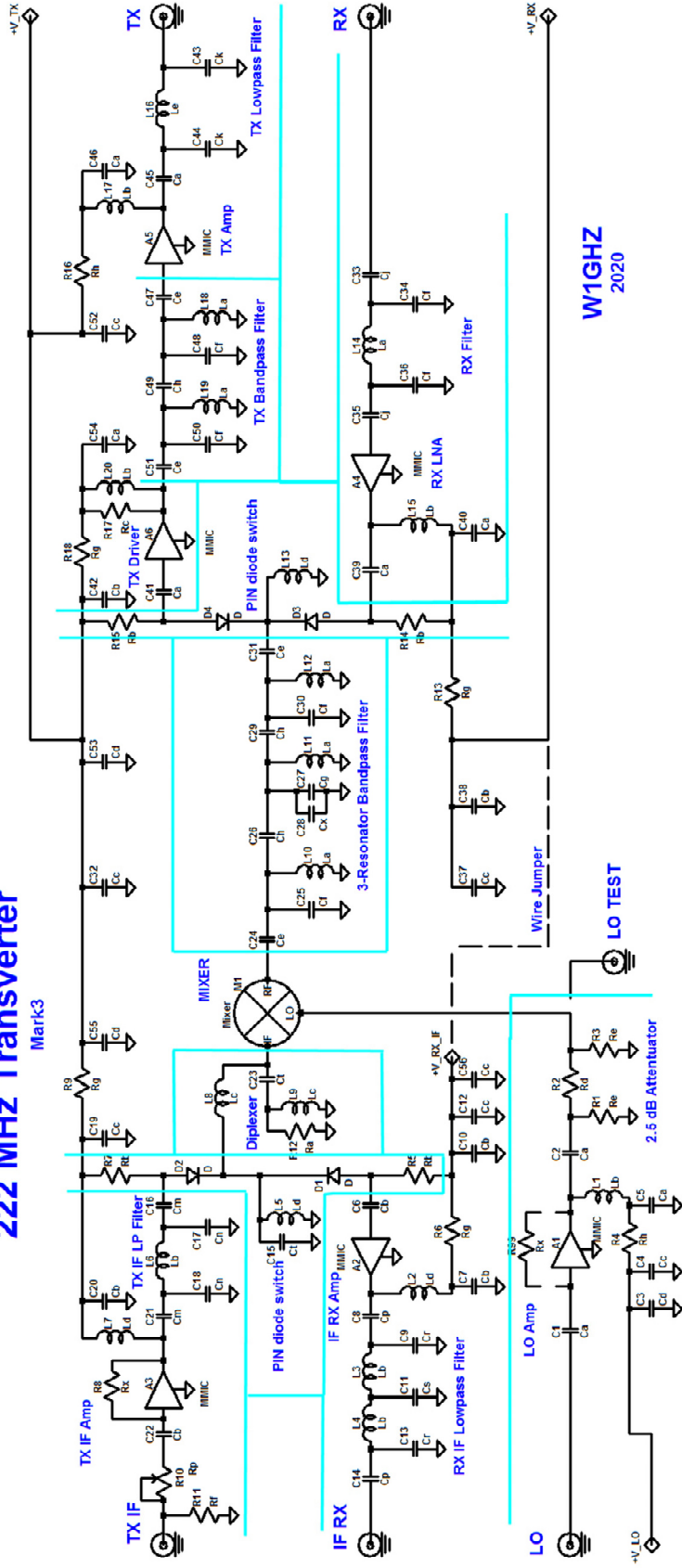

Figure 1 - 222 MHz Transverter

222 MHz Transverter

Mark3



W1GHZ
2020

Circuit

As I considered modifying a G4DDK Anglian3L board for 222 MHz, I analyzed and simulated each section using Ansoft Designer SV (Student Version) free software. Then I calculated new component values for 222 MHz and re-simulated. The filters are good ones, well designed, and not easily improved on, so I pretty much copied the RF circuits. When I built the prototype, I assembled the filters first and measured each one individually. The results are shown in the Filters Appendix.

The main bandpass filter, comprising three coupled resonators, is at least as good as the helical filters used in my previous transverters. It has a passband about 12 MHz wide, shown in Figure 3, and about 50 dB of rejection at the local oscillator frequency, 194 MHz. The filters use Coilcraft tunable inductors for the main filters, and SMT (Surface Mount) chip inductors for the less critical ones, as well as ordinary chip capacitors. Coilcraft seems to be one of the few companies that doesn't obsolete components quickly, and the active devices are MMICs from MiniCircuits, another good supplier, so this transverter design may have a longer lifetime.

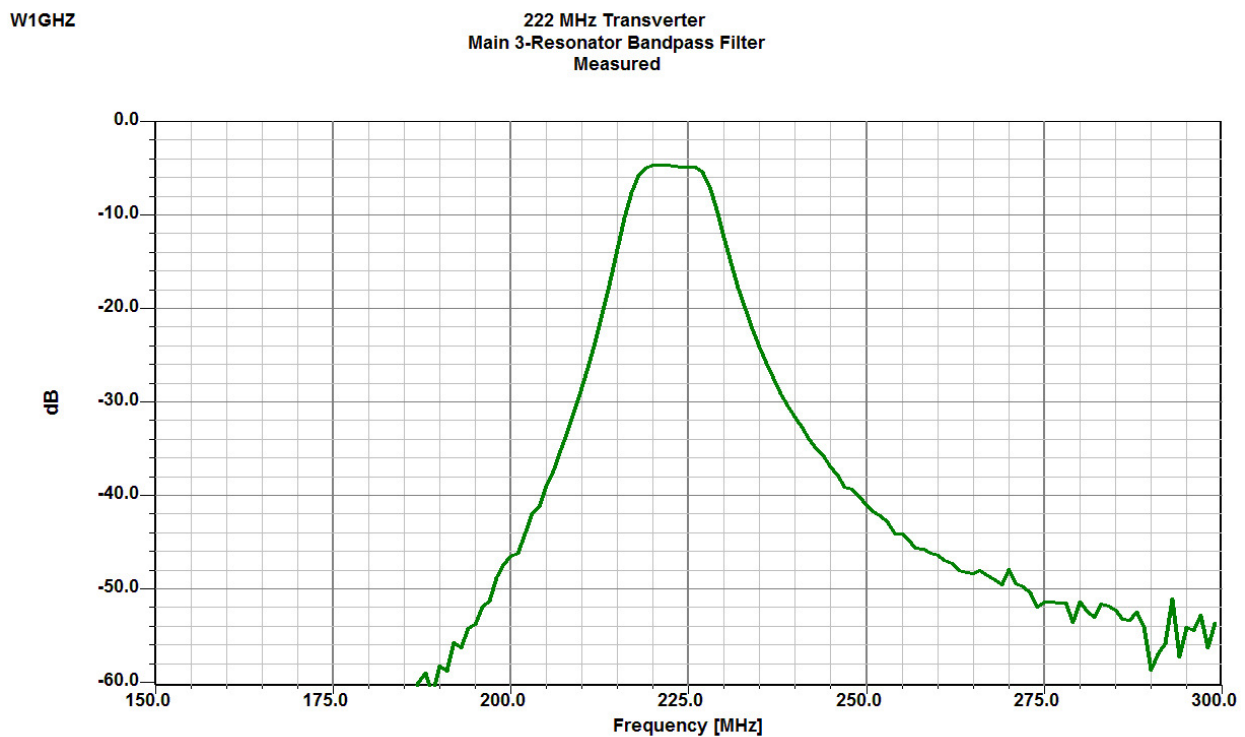

Figure 3 – Performance of main bandpass filter

The schematic diagram in Figure 2 has the functional blocks delineated; a clean schematic is also included later for construction use. At the heart of the circuit is the mixer, followed by the main three-resonator bandpass filter, which together produce the 222 MHz signal by mixing the local oscillator frequency (194 MHz) with the IF frequency (28-30 MHz), to cover 222-224 MHz. To

the left of the mixer is the IF part of the transverter, while the RF (222 MHz) is to the right. The same mixer also operates on receive, converting the frequencies in the opposite direction.

The LO (local oscillator) is produced off-board, in a synthesizer, or a crystal oscillator if you can find a good crystal – they are getting rare and expensive. On the PC board is an LO amplifier to produce the required LO power, around +7 dBm for a standard double-balanced mixer or +17 dBm for a high-level mixer, if higher dynamic range is needed. Between the LO amplifier and the mixer is a small attenuator, so that the mixer sees a good 50 ohm termination – properly terminating a mixer results in lower loss and better dynamic range. In my 432 MHz transverter⁶, I found that at least 2 dB attenuation was needed to reduce interaction between the LO amplifier and the mixer. More attenuation is fine, if needed to reduce excess power.

On the RF side, a simple PIN diode switch selects either TX (transmit) or RX (receive) when that direction is powered. We never power both at once.

The RX LNA (Low Noise Amplifier) has a simple RX filter at the RX antenna port for low loss so the noise figure is not degraded. In areas with strong signals at nearby frequencies, such as TV Channel 13, a good external bandpass filter will be required anyway.

The transmit chain has more filtering to produce a clean signal. Two stages are needed to produce enough output power to drive an external amplifier module – there are several choices for a module, but obsolescence is a problem, so it is kept separate. Between the two stages is an additional two-resonator bandpass filter, and there is a simple low-pass filter after the TX amplifier to reduce harmonics.

The IF side, working out from the mixer, starts with a Diplexer, which passes frequencies at or below the IF frequency while rejecting higher frequencies, and looks like a good 50-ohm termination to the mixer at all frequencies. After the diplexer is another PIN diode switch to separate the RX and TX, again selected by either the TX or RX voltage.

The IF RX has an amplifier MMIC to provide more RX gain – if the additional gain was at the RF frequency, before the mixer, it could limit the dynamic range. The RX amplifier is followed by a low-pass filter, to keep any stray LO or RF signal out of the IF transceiver.

The IF TX has a resistive divider to adjust the input power level, followed by a MMIC amplifier and then low-pass filter to keep any undesired signals from reaching the mixer – the transverter port on some transverters may not be as well filtered as the antenna port. The TX IF amplifier may not be needed if the transceiver produces enough signal to drive the mixer (~0 dBm max). This is one of the many optional choices to make as the transverter is built into a system.

Options and Choices

The transverter board is only the RF part of a system, and is intended to be flexible for use in a range of system, depending on component choice and how the board is populated. The basic board has separate transmit and receive on both IF and RX ports, and the local oscillator is not included. Some transceivers have separate transverter ports. If not, a separate IF interface may be needed. My “Simple, yet Fool-Resistant Sequencers⁷” provide an IF interface that can have single or separate RX and TX on both transceiver and transverter sides, as well as providing the sequencing control for the whole system.

The first choice, mentioned above, is the TX IF amplifier. With many IF sources, with adequate power available, it is not needed, and is not recommended. Excess gain here will only amplify the transmit phase noise of the IF transceiver. To omit the TX IF amplifier, the A3 MMIC is left out and Rx, a zero-ohm resistor (or wire) added instead. The RF choke, L7, is also superfluous and may be omitted. If the IF transceiver can control the output level conveniently, R11 may be omitted and R10 replaced with a jumper as well.

For the simplest system, the TX IF port could be used for both transmit and receive, with no amplifiers. The PIN diode switch is eliminated as well, omitting D1 and replacing D2 with a zero-ohm resistor. The IF RX section would be omitted entirely as well, but RF gain would be rather low and weak signal performance could suffer.

The biggest choice is the mixer and LO combination, as well as the local oscillator source. A popular LO synthesizer is the digiLO from Q5 Signal (q5signal.com), with an output of level of +2 to +4 dBm at 194 MHz. At this LO power level, the standard mixer will still operate, but with reduced performance. The standard mixer (Minicircuits ADE-2+) prefers +7 to +10 dBm, so the LO amp is needed. In this case, I prefer the MAR-4+ for MMIC A1, with about 8 dB of gain. A higher gain MMIC may be used, changing the attenuator to provide the right LO power; see the ARRL Handbook for resistor values. I power the LO amplifier from the same 8-volt three-terminal voltage regulator that supplies the digiLO, so R4 is 56 ohms. See the MMIC data sheet for other MMICs and voltages.

For higher dynamic range, hardly needed around here but important on mountaintops and in high activity areas, a high-level mixer is needed. The Minicircuits ADE-1H+ needs an LO power of about +17 dBm, 50 milliwatts, for best performance, so a higher gain and power MMIC is needed. G4DDK says that an even higher LO power, +20 dBm, can increase the dynamic range slightly. I found that the Minicircuits PHA-1+ worked best in my 432 MHz transverter, with the PSA4-5043+ also working well. For maximum gain and power, R4 is zero ohms. The 2.5 dB attenuator is about right.

The LO TEST port is available for measuring LO power level or testing other parts of the circuit. Before adding the mixer, add a capacitor (300 to 1000pf) from the trace near R2 to the LO TEST port and add an SMA connector. If adequate LO power is available, or if you wish to do some

initial testing with a signal generator, connect the LO test port with the capacitor and leave out R2 and R3. Without a mixer, a jumper from the mixer LO pin to the RF or IF pin allows testing and tuning of those sections.

The TX Driver and TX Amp MMICs (PGA-105+) are chosen to provide a nominal +10 dBm TX output without excess gain. For higher output power, a GVA-84+ TX Amp A5 will do. A higher gain TX Driver can push a bit more, but add R17 for stability.

The RX LNA is a PSA4-5043+, providing good gain and noise figure with good dynamic range. For ultimate dynamic range, especially with an external preamp, a PHA-1H is suggested, and a good external bandpass filter is essential.

Other IF frequencies are possible. For instance, I have considered using a 200 MHz VCXO, splitting the output, adding a doubler to 400 MHz for 432, resulting in a 22 MHz IF for 222 and a 32 MHz IF for 432. The IFs could be combined in a diplexer to feed an SDR with multiple receiver slices, to monitor both bands simultaneously. Changing the IF frequency requires modifying the IF low-pass filters. The LO is untuned and requires no modification.

Other MMICs may be used if my choices aren't available (note: Minicircuits will provide a few free samples of most parts if you fill out the online request form – just say for ham radio).

Construction

Consider the options above and decide on your choices before you put all the parts down. In particular, think about whether you will use the LO TEST port (see Test and Tuning below), or just put it together and hope it all works.

I have tried to make this transverter easy to build, at least if you can work with surface-mount components. All the parts are on one side of the board except for the tunable inductors, and I have tried to separate them enough to hand solder. All the component designators (C32, R48, etc) are labelled on the board in silkscreen, and I have re-sequenced them so they are in order on the PC board, shown in Figure 4, along with the functional blocks. The component designators start in the upper left in the LO section, then continue down each functional block in turn, starting at the left in the RX-IF block. Comparing this photo with the schematic functional blocks in Figure 2 should make it easy to locate any component.

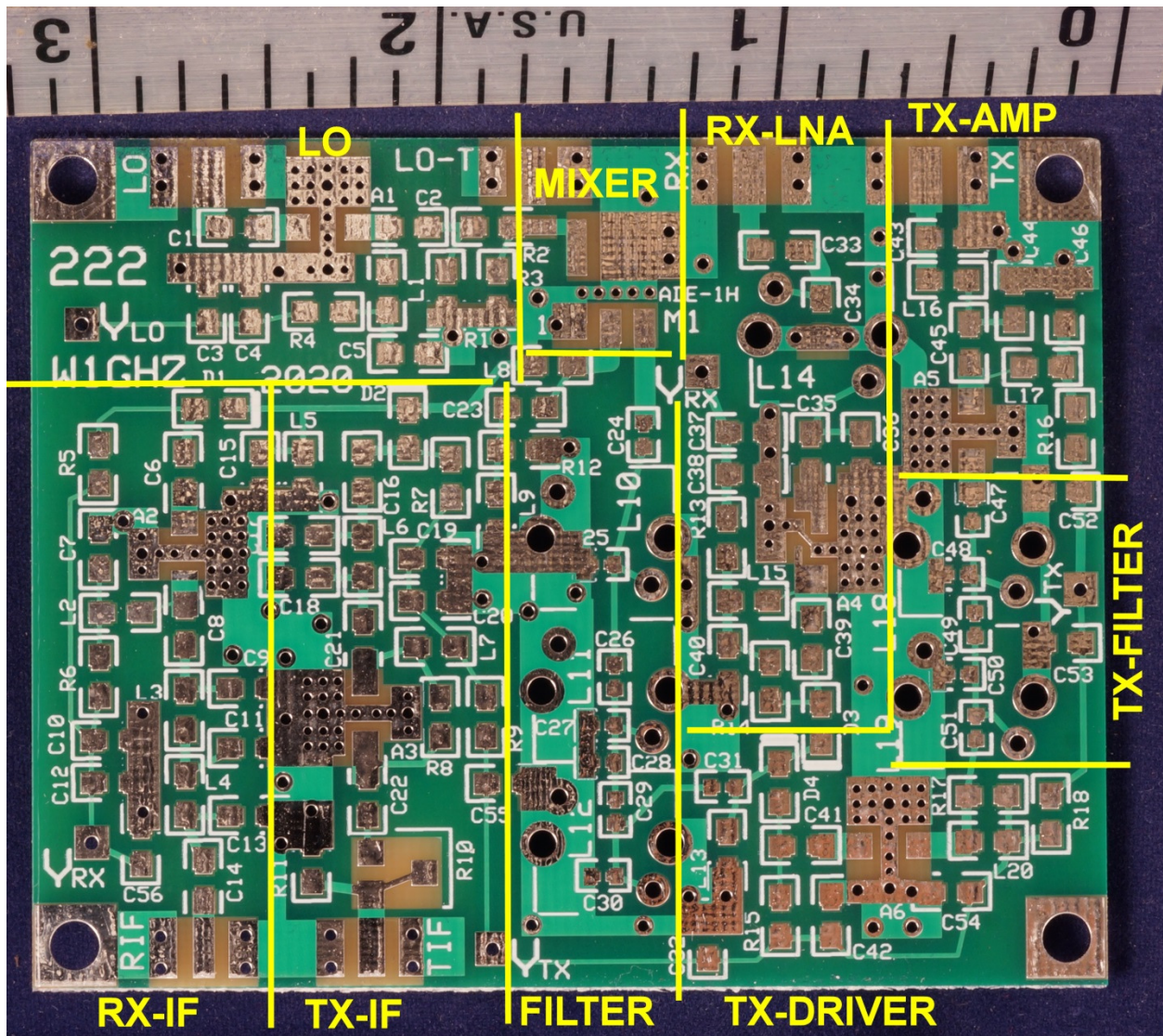

Figure 4 – Bare PC Board with functional sections outlined

- **Surface Mount Components**

To solder a surface-mount component, I use a temperature-controlled soldering iron set at about 600°F (using the thermonuclear setting just causes damage much faster) and thin (0.015 diameter) 63-37 tin-lead solder. I put a small puddle (not a lake) of solder on one pad, place the component in position with tweezers, and reheat the puddle to solder one end of the component, making sure it sits flat. If it isn't down flat, a quick quick reheating while pushing down on the component should fix it. Then solder the other end of the component. Both ends of the component should end up with a nice solder fillet – see Figure 5. If not, resolder with a little fresh solder. After a little practice, total heating time for a component is under 15 seconds, which won't hurt anything.

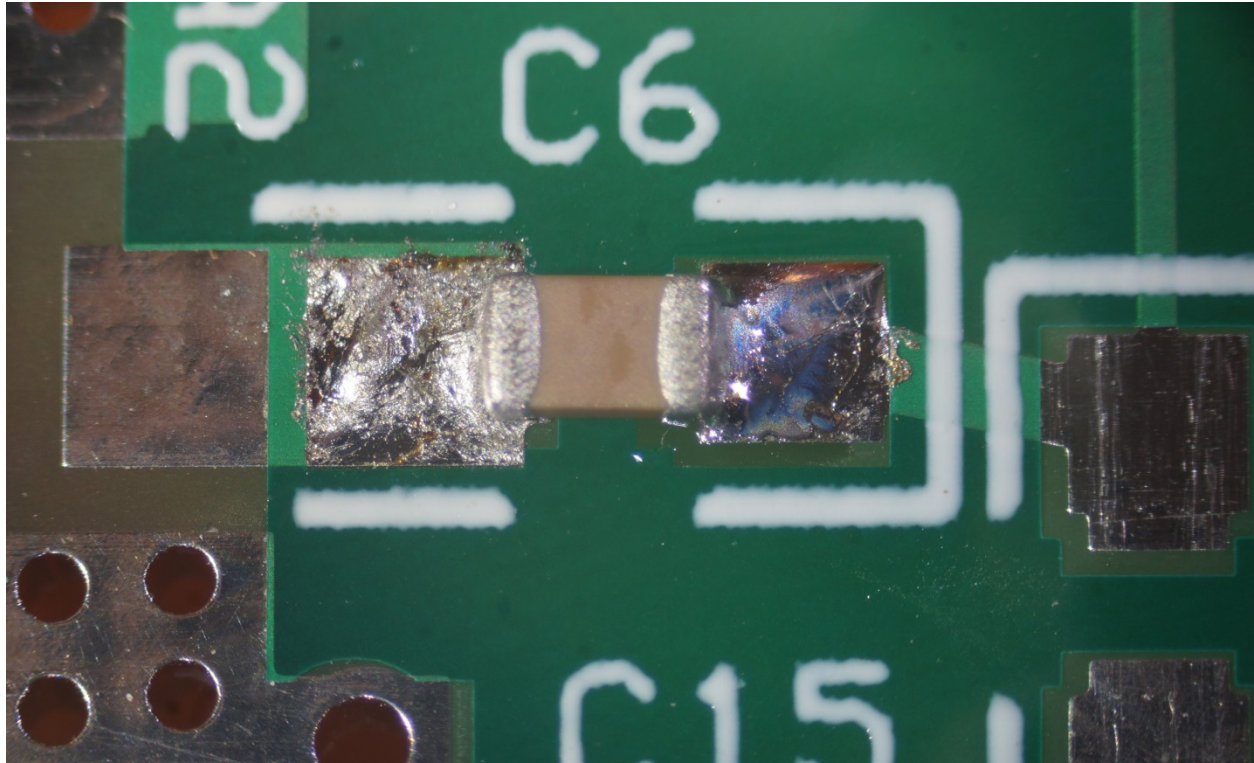

Figure 5 – SMT soldering. Good solder fillet on right, left side needs reflow

Once in a while, things don't go smoothly and everything looks ugly. Remove the component (SMT parts are cheap), throw it over your shoulder, clean the pads, and start over with a new component. You did buy spares, didn't you? Occasionally, my tweezers slip and the part goes flying somewhere – I don't even look for it, because I couldn't tell it from the others on the floor anyway.

A few parts need special consideration. I try to use reasonably sized SMT components, 0805 size (0.08 x 0.05 inches), and I use PCB footprints that will accommodate larger (1206) and smaller (0603) sizes to provide some flexibility. However, it is hard to find low-value capacitors, less than 3 pf, in the 0805 size, only in smaller sizes. So I created new footprints that accommodate 0805 and smaller sizes, down to 0402. The smaller part is shown in Figure 6. These are harder to work with, so be sure to have spares. I'd suggest putting the small capacitors in first, with nothing in the way. (Note: cellphones use even smaller parts, 0201 size, which look like grains of sugar).

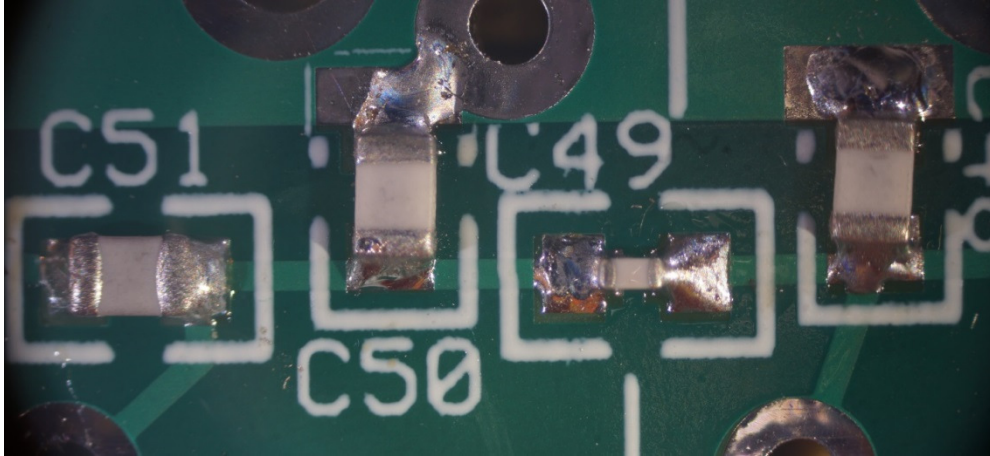

Figure 6 – Some capacitors are only available in small package sizes (C49)

The larger capacitor values, over 300 pf are less critical. The 330 pf caps are for DC blocking and RF bypass – low impedance for RF, but an open circuit for DC – so any value between about 270 pf and 1000 pf will work. The 0.1 uF caps are for low-frequency bypassing, and the 1uF caps are for audio bypass. Any size up to 1206 should be OK for any of these capacitors.

The PIN diodes require correct orientation. The component outline on the board has a heavier bar on one end to match the bar on the diode, as shown in Figure 7. Even with this reminder, I still manage to put one in backwards about 10% of the time.

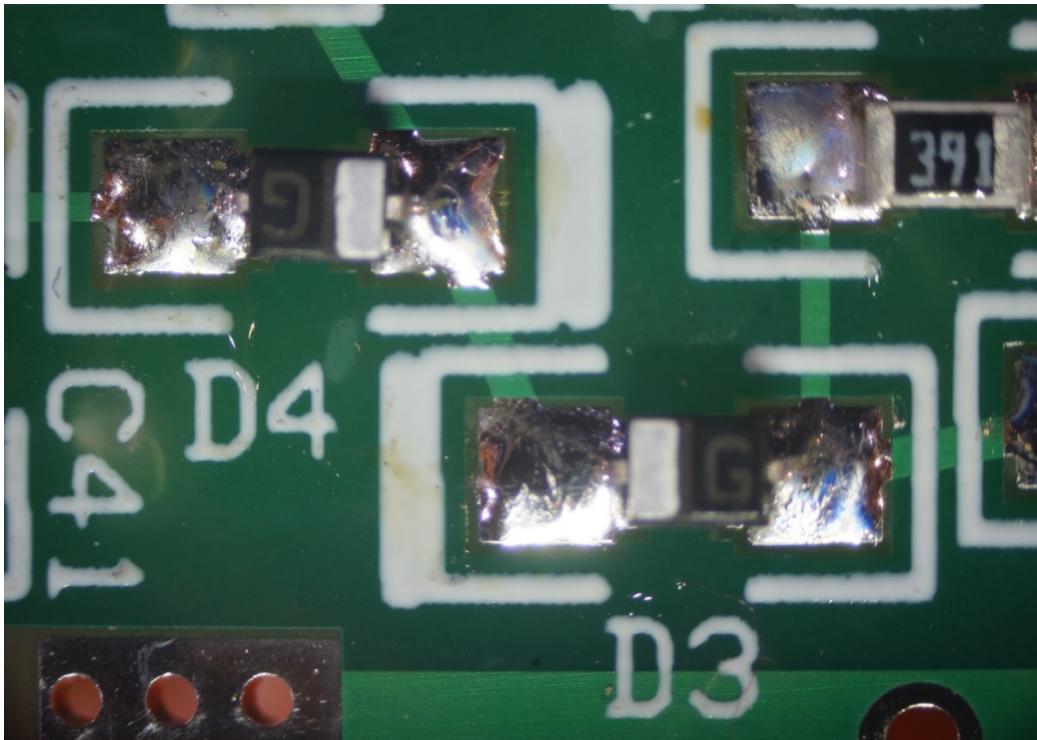

Figure 7 – PIN diode orientation

- **Inductors**

Inductors also require special handling. The SMT ones have pads on the bottom, so the solder must be flowed under them and inspected at an angle afterward. Take care when pushing them down, as some of them have soft plastic covers with very fine wire underneath. A check with an ohmmeter will assure that they are connected.

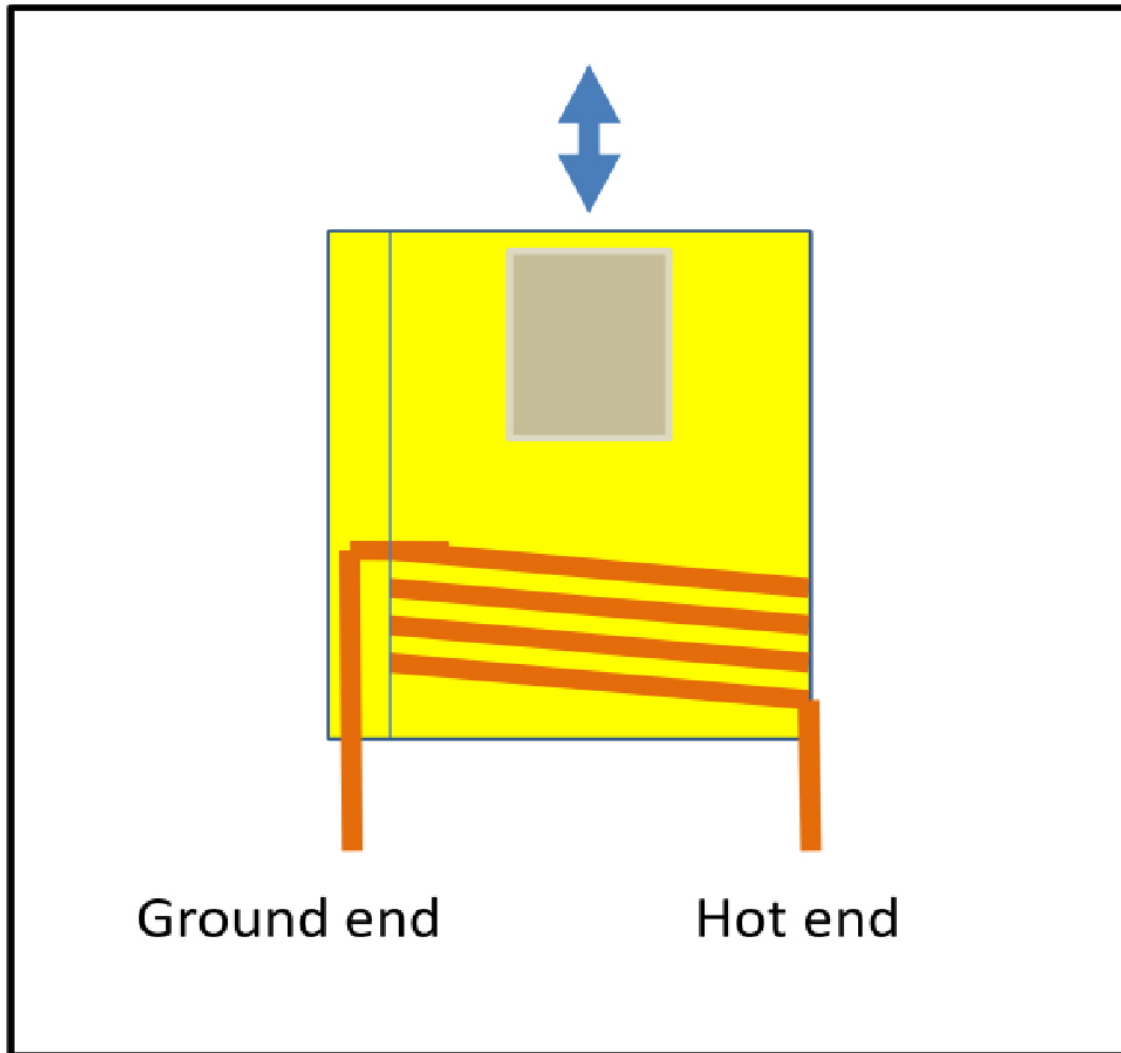

Figure 8 – Tunable Inductor Orientation (courtesy G4DDK)

The tunable inductors must be inserted in the correct orientation with the top end of the coil connected to ground, according to G4DDK, and shown in his sketch in Figure 8. Since the shield can hides the coil, the can must be removed. Grasp both pins with needle-nose pliers, squeeze the sides of the can without the ground tabs, and the coil should slide out. One corner of the plastic coil form is fatter than the others – this is the hot end. The coils should be inserted in the PC board from the ground plane side in the orientation shown in Figure 9, with all the fat corners in the same direction.

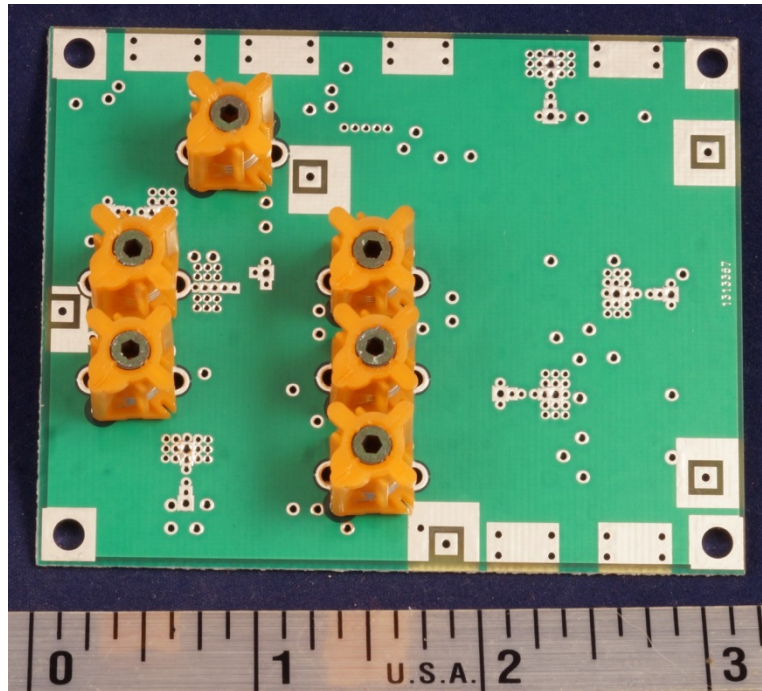

Figure 9 – Tunable inductor placement and orientation – note fat corner

After soldering the pins, the shield cans can be added and soldered, except for the RX filter coil, L14. G4DDK suggests leaving this can off for higher Q and lower loss, and I haven't seen otherwise. See Figure 10 for final configuration.

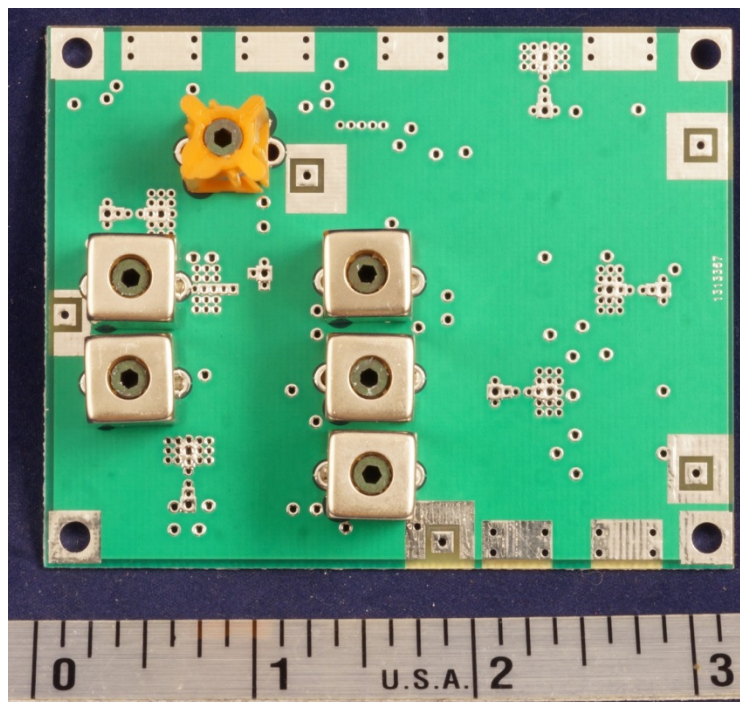

Figure 10 – Tunable inductors have shield cans except L14, as shown

- **MMIC assembly**

The RX MMIC, A4, a PSA4-5043, is quite small and is easy to get the orientation wrong. Figure 11 shows correct orientation.

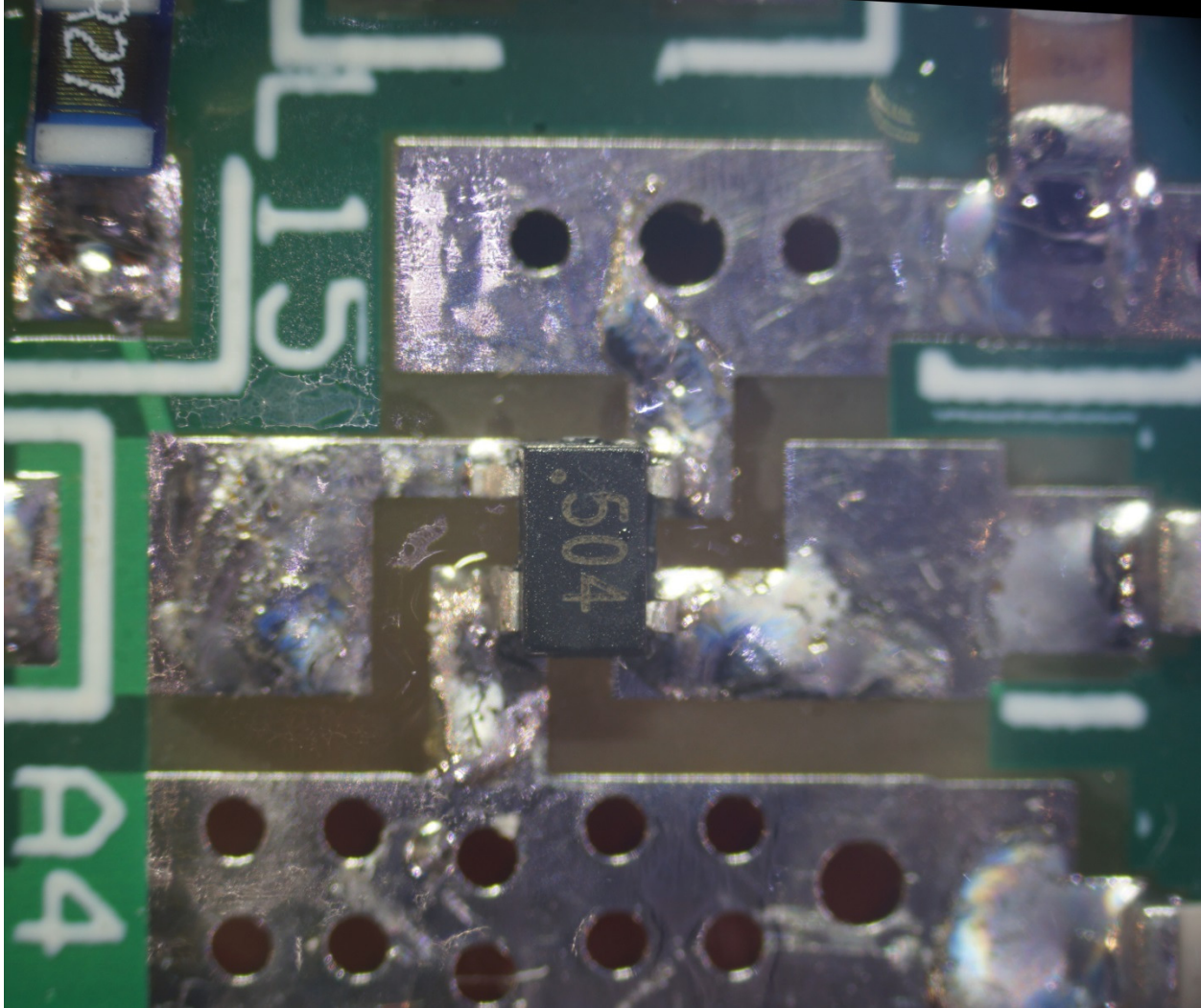

Figure 11 – Correct orientation of A4 MMIC (RX LNA)

The MMICs in the SOT-89 package, three terminals with ground tab, need a good ground connection for RF and for heat sinking to the PC board. To ensure this, I flow solder onto the ground areas of the board under the tab and center lead, enough to fill the holes, flowing it sufficiently to leave it flat. Then I add a puddle of solder on the output lead and attach the output lead, making sure the ground tab sits flat. Next I use a soldering iron with a larger tip, heat the board next to the tab, and add more solder so it flows under the part. When the solder under the center lead melts onto the lead, remove the heat. Since the device temperature has barely reached the melting point of solder, no damage can occur. Finally, solder the input lead and touch up the output lead if necessary. A finished part can be seen at A1 in Figure 12.

- Mixer and LO

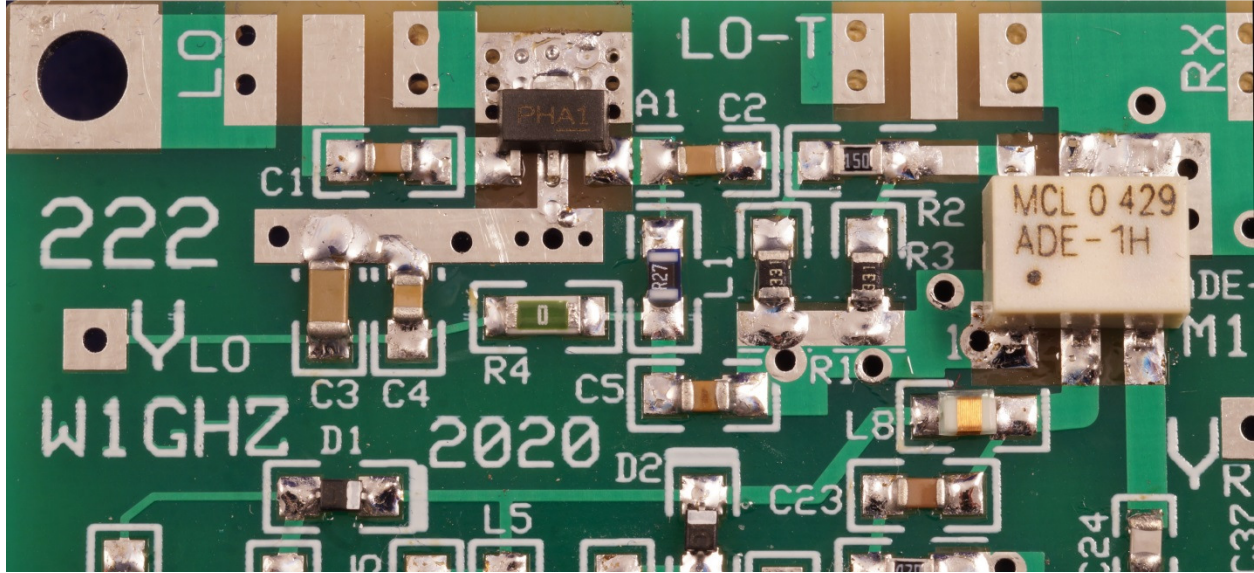

Figure 12 – Mixer and LO amplifier for high dynamic range option

Among the options described above is a high dynamic range mixer which requires more LO drive. Figure 12 shows this area of the PC board assembly for high dynamic range, while Figure 13 shows a standard mixer and lower gain LO amplifier.

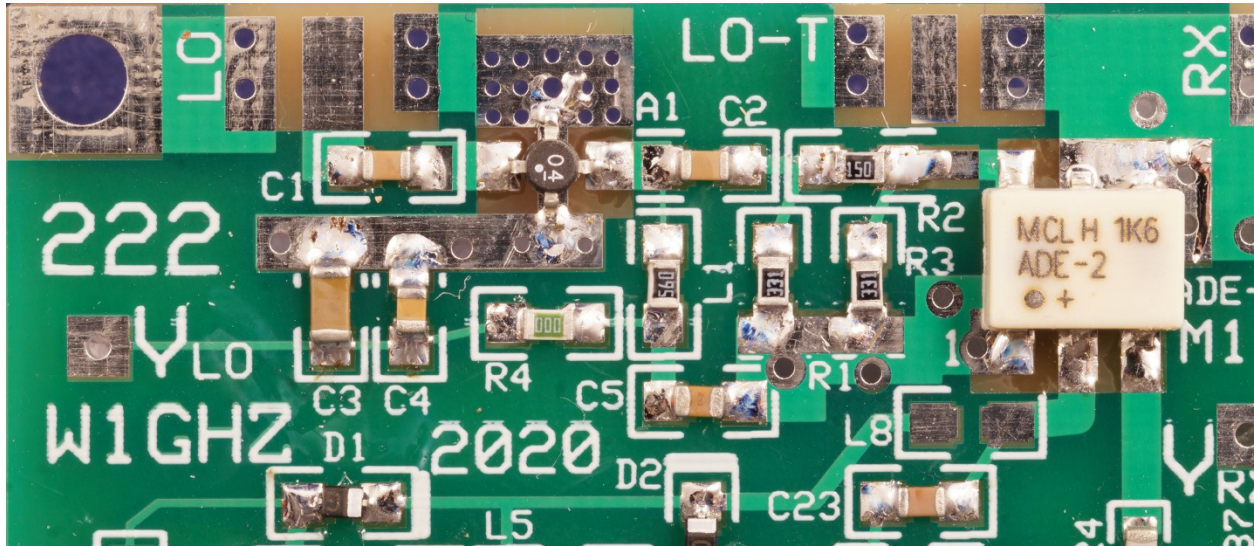

Figure 13 – Mixer and LO amplifier with standard mixer

- **SMA Connectors**

The PC board is designed with edge-mount SMA connectors in mind, but pigtails will work fine at these frequencies. Using SMA connectors will make testing and tuneup easier. Be sure to solder them to both top and bottom of the board. Inexpensive SMA connectors from China work fine at these frequencies and are available for \leq \$1.

- **Jumper wire**

Finally, don't forget the jumper wire between the two V_{RX} pads, best run on the ground plane side of the board. Jumper wires are much better than breaking up ground planes to run a trace. While you are looking at the ground plane side, it wouldn't hurt to label the voltage pads and RF connections with a Sharpie.

- **Schematic**

A clean schematic is shown in Figure 14. A .pdf version is also available for printing and marking up as you assemble the board.

- **Test and Tuning**

The LO-T pad, for an additional SMA connector, is included to make test and tuneup easier. If you are going to use it, leave out R1, R2, and the mixer. Add a temporary capacitor, 1000 pf, from the LO-T pad to the nearby trace which connects R2 to the mixer.

Each of the sections of the board (see Figure 4) can be tested by adding a jumper across the mixer pads, from LO to IF to test the LO sections, and from LO to RF for the RF sections.

The first section to tune should be the transmit RF section, which includes the main FILTER, the TX-DRIVER, the TX-FILTER, and the TX-AMP. If you have used the specified parts, both filters should be close enough to frequency so that each tunable inductor core needs only a turn or two to peak – start counter-clockwise.

Apply +5 Volts to a V_{TX} pad, then a small input signal, perhaps -10 dBm, at 222 MHz to the LO-T connector. Look for output at the TX connector and peak the inductor cores for maximum output. To peak properly, the input signal may have to be reduced to avoid saturating the amplifiers. If you have a sweep generator or network analyzer, tuning the filters is easier. (Hint: a NanoVNA, covering 1 to 1500 MHz, is less than \$60, and also does a great job as an Antenna Analyzer.)

The other sections are tested in a similar fashion, using the appropriate jumper, SMA connector, and voltage pad. The PIN diode switch is selected for transmit or receive by the voltage applied. Only the RX-LNA needs tuning; the IF sections can get a quick check.

222 MHz Transverter

Mark3

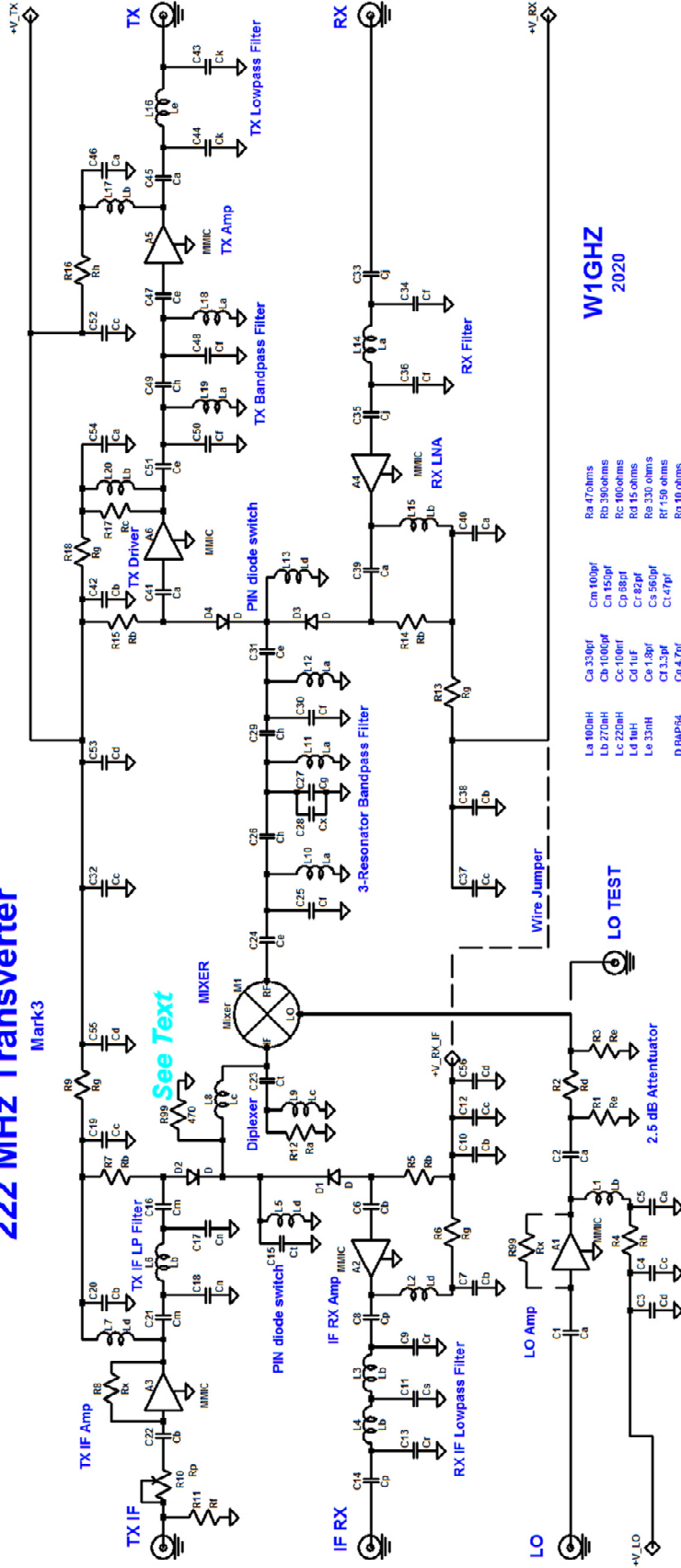

W1GHZ
2020

Ra 47.0ohms	Rb 390ohms	Rc 100ohms	Rd 15.0ohms	Re 230.0ohms	Rf 150.0ohms	Rg 10.0ohms	Rh 15.6 or 22.0 ohms	Rp 500ohm trimpot
Cm 100pf	Cn 150pf	Cp 88pf	Cr 82pf	Cs 560pf	Ct 4.7pf	Cx see text	Cy 0.22pf	Cz see text
Ca 330pf	Cb 1000pf	Cc 100nf	Cd 1uf	Ce 1.8pf	Cf 3.3pf	Cg 4.7pf	Ch 0.22pf	Ci 8.2pf
La 100nH	Lb 270nH	Lc 220nH	Ld 1nH	Le 33nH	D BAP54			

LO TEST

2.5 dB Attenuator

See text

Finally, the LO Amp is tested by removing the jumper and adding R2 and R3 to the board. With appropriate V_{LO} applied, signal is input at the LO connector and detected at the LO-T connector. If the actual LO source is used, the LO level at the mixer may be measured.

Inspect carefully, and when everything looks good (you may be lucky, but I usually find something that needs fixing), remove the temporary capacitor, clean the mixer pads, and solder the mixer in place. Refer to Figure 12 or 13 for proper alignment – it is easy to get wrong.

Glitch

Everything was looking good, until sometime during testing, I was looking at the RX IF output with a spectrum analyzer and happened to turn the LO off. A huge signal at around 12 MHz appeared, with multiple harmonics. Powering one section at a time narrowed it down to the IF RX amplifier, which appeared to be oscillating with no LO applied – the mixer impedance changes without LO. Simulation of the Duplexer showed that it was a poor termination at low frequencies, and the resonant frequency of L5 in parallel with C15 is around 10 MHz.

Perhaps adding some resistance in parallel with L5 would lower the Q enough to prevent oscillation. At this low frequency, lead inductance isn't important, so I poked around with some quarter-watt resistors, and found that 470 ohms tamed the oscillation, while 680 ohms only reduced the amplitude. Looking closely at the board, I found that a larger chip resistor, 1206 size, would fit between D2 and the ground pad of C5, as shown in Figure 15. With this resistor, the oscillation is gone. Gain is reduced by perhaps a dB, and Noise Figure might be a hair higher. The resistor is added to the schematic as R99, shown in Figure 15. The next batch of PC boards should have this resistor included.

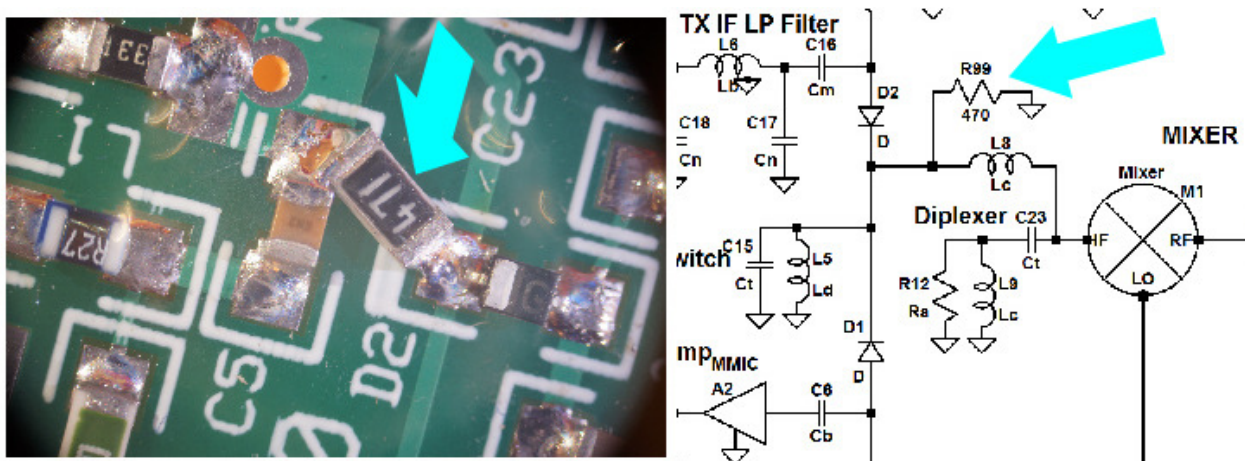

Figure 15 – R99 added on board and schematic

Power Amplifier

This board is intended to drive a power amplifier module, and several choices are possible. A small 5 to 10 watt MOS module is plenty to drive modern solid-state power amplifiers. Figure 16 shows 7-watt module a small PC board with a low-pass filter on the output, and the schematic diagram is Figure 17. This module operates at about 8 volts, so a voltage regulator with 2-amp capability is needed. For higher power, 30-watt modules are available new from RF Parts, and surplus ones have been showing up on ebay at very attractive prices.

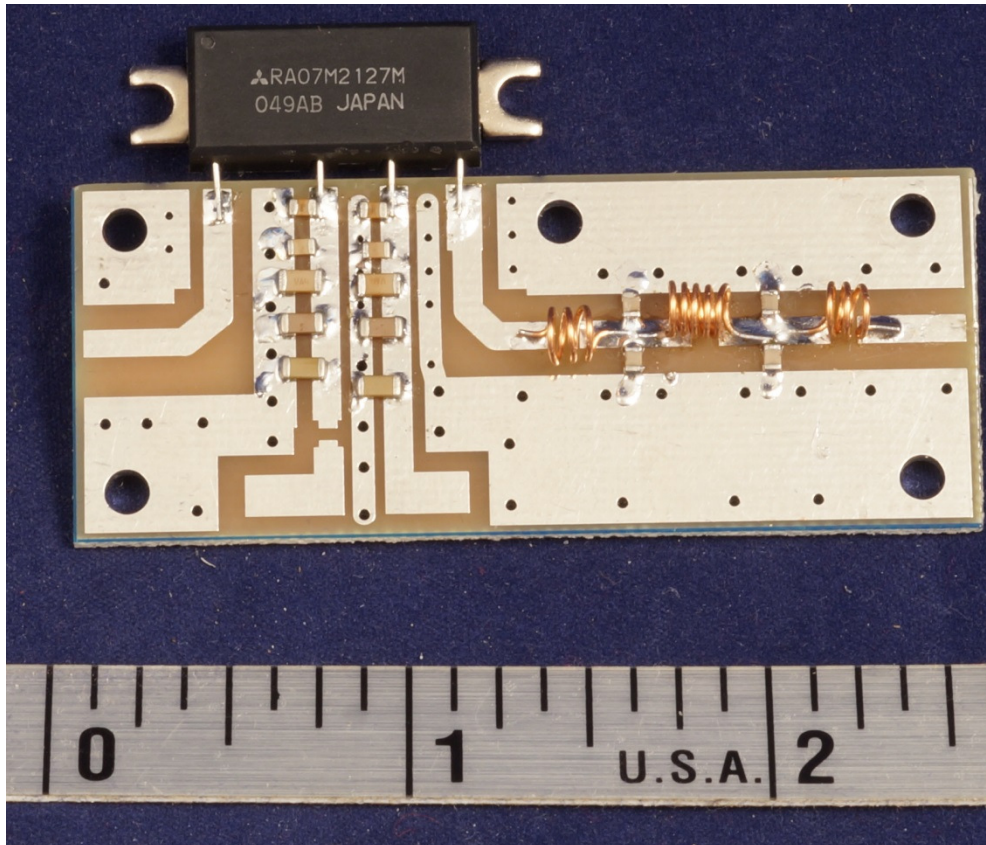

Figure 16 – MOS amplifier module with low-pass filter on output

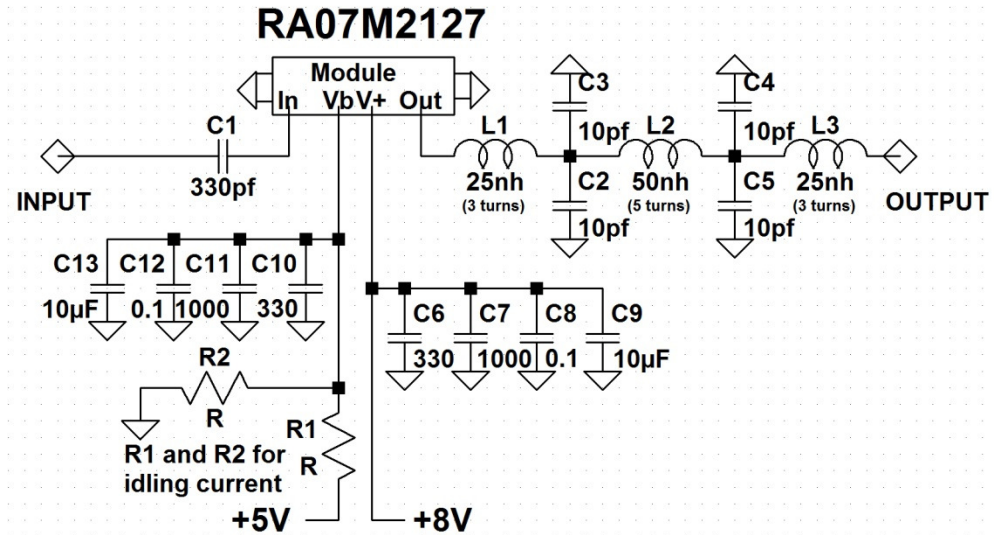

Figure 17 - 7 Watt Power Amplifier schematic

The low-pass filter on the output of the module is to suppress harmonics, with about 26 dB of rejection at 444 MHz, the second harmonic, and roughly 50 dB at 666 MHz. The coils are #22 wire wrapped around a #33 drill (0.118" diameter – 1/8" is probably close enough). The filter is tuned for best VSWR before the module is in place, from an SMA connector at the module out pad to an SMA connector at the OUTPUT. VSWR can be measured with a network analyzer like the nanoVNA, or an Antenna Analyzer with a 50-ohm load at the other end. Tuning is accomplished by squeezing the turns of the coil together or stretching them apart. Figure 18 shows what a little tweaking of the coils can do.

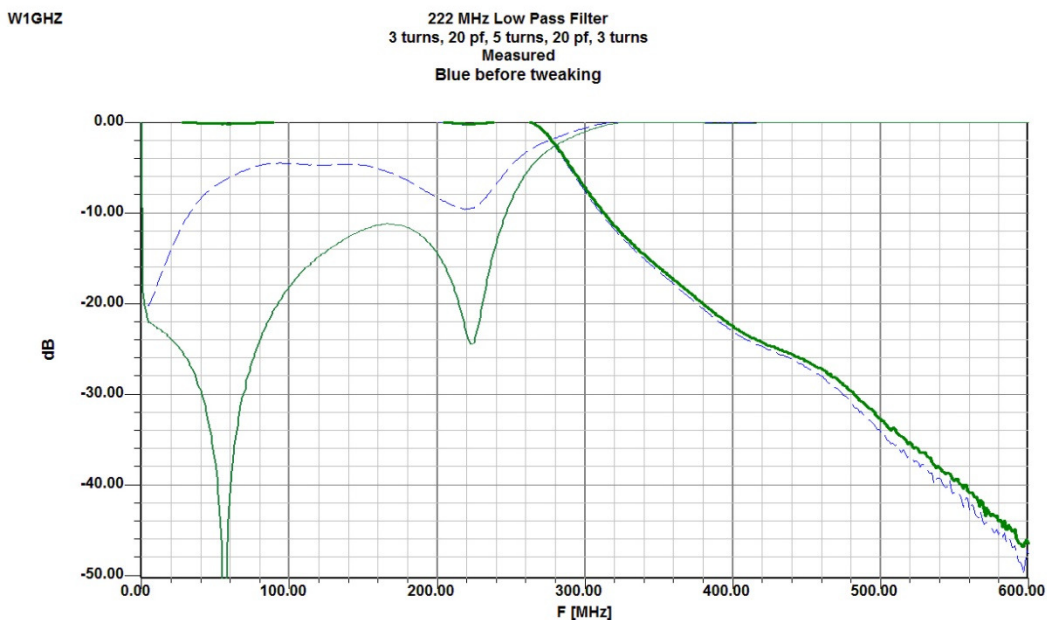

Figure 18 – Low pass filter on PA – before and after tweaking

Complete Transverter

A complete 222 MHz transverter in a die-cast housing is shown in Figure 19. The transverter board is in the center, mounted with component side down. The local oscillator, a digiLO is inside the Altoids tin on the left hand wall, and the Fool-Resistant Sequencer is on the right-hand wall. All external connectors are on the near wall, which will be the rear. On the far wall is the power amplifier module – the die-cast aluminum box acts as the heat sink. Voltage regulators for the local oscillator and for the power amplifier module on the near wall, spreading out heat sinking. The sequencer supplies 12 volts for transmit or receive, and the 5-volt 3-terminal regulators on the corners of the transverter reduce the voltage to 5 volts for V_{TX} or V_{RX} .

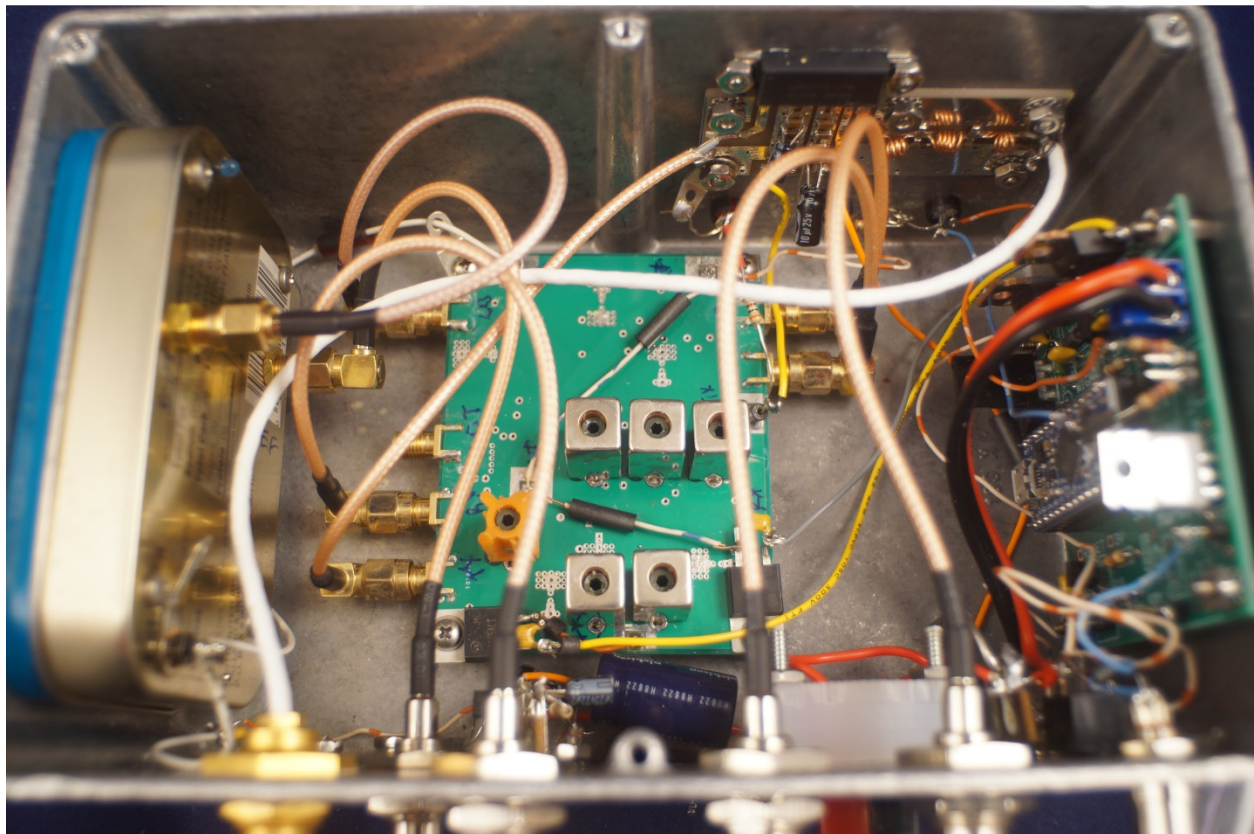

Figure 19 – Complete 222 MHz transverter in die-cast aluminum enclosure

This version is intended to work with an SDR with separate transmit and receive ports, providing a few milliwatts on transmit, so no IF interface is needed. The 222 MHz output is intended to drive an LDMOS solid-state power amplifier, and the receive line will have a good filter and possibly a remote preamp. The TR relay would be after the SSPA, but can be driven by the sequencer in the transverter.

Of course, a transverter system could easily work with a conventional transceiver, with a single IF port. The some versions of the Fool-Resistant Sequencer include an IF interface with PIN

diode switch. I plan to build another transverter for roving with an FT-817, perhaps with a higher power PA module.

Performance

Performance of the transverter meets my expectations and is better than any of the 222 MHz transverters I have had. On receive, noise figure is under 2 dB, with about 25 dB of gain. Transmit power depends on the MMICs chosen – the one in Figure 19, with a PGA-105 as final amplifier A5, puts out about +10 dBm with about 10 dB transmit gain. A second unit, with a GVA-84 at A5, has a 1-dB compression point about +20 dBm with about 20 dB gain.

The filters in the transverter do an impressive job, with LO and image more than 70 dB down – I can't find them with the spectrum analyzer. Harmonics measure -48 dB 2nd, -58 dB 3rd, and -65 dB 4th.

My QTH is line-of-sight to all TV and FM broadcast stations, including Channel 13, so noise and overload can be a problem. I have a comb-line filter⁸ in front of my preamp – without the filter, the noise floor with my old transverter rises 25 dB toward the mountain, compared to a quiet direction, but only 3 dB with the filter. With this transverter, with standard-level mixer, the noise rises 5 dB without the filter. Much better, but I'll still use the filter.

I haven't done any IMD testing, so I don't know if the high-level mixer really helps. What I did see is that the noise figure of the transverter with the high-level mixer is sensitive to LO drive level. Best NF is at a lower LO level than would be needed for best IMD. Since the high-level option burns a lot more power, I'd suggest sticking with the standard-level mixer unless IMD is a real problem.

Kits

PC boards are available. However, it takes nearly as long to sort the parts and assemble a kit as it does to solder them onto a board, and isn't as much fun. Instead, a Mouser project parts list is available for one-click ordering, with quantities including spares (searching for a dropped SMT component is futile) totaling less than \$50 – the helical filters in the previous designs cost more than that. A group or club project can be fun and save on quantity purchasing.

Summary

This 222 MHz transverter should be easier to build and test than previous versions, and parts should be available for a reasonable amount of time. It can be the heart of a transverter system at whatever performance level you choose.

PC boards are available, and Minicircuits parts are now available from Mouser.

Notes

1. Paul Wade, W1GHZ, "A 222 MHz Transverter for the Yaesu FT-817," *QST*, January 2003, p31.
2. Paul Wade, W1GHZ, "A 222 MHz Transverter for the Yaesu FT-817," *QST*, January 2017, p35.
3. Sam Jewell, G4DDK, A Modern 144 MHz Transverter, *EME 2014*, ORPB, 2014.
4. Sam Jewell, G4DDK, John Regnault, G4SWX, & Jason Flynn, G7OCD, "A high performance 144MHz transverter and power amplifier - The Anglian," *DUBUS*, 3/2014, p. 62.
5. Sam Jewell, G4DDK, "The 144 MHz Anglian 3L Transverter," *DUBUS*, 3/2017, p. 97.
6. Paul Wade, W1GHZ, "432 MHz Transverter for an SDR," *Proceedings of the 44th Eastern VHF/UHF Conference*," (CD), 2018. www.newsvhf.com
7. Paul Wade, W1GHZ, "A Smart Fool-Resistant Conditional Sequencer," *Proceedings of Microwave Update 2018*, ARRL, 2018. www.w1ghz.org
8. Paul Wade, W1GHZ, "Comblne Filters for VHF and UHF," http://w1ghz.org/filter/Comblne_Filters_for_VHF_and_UHF.pdf

Appendix – 222 MHz Transverter Filters

All the filters in the 222 MHz Mark3 transverter were measured individually, in place on the PC board, before MMICs and other components were added.

The main filter is a three-section bandpass filter using tunable Coilcraft inductors in shield cans. The schematic diagram is shown in Figure A1. Figure A2 shows the response before tuning (dashed line) and after (solid lines) tuning – not much tuning is required. The final result is nice flat 12MHz bandpass.

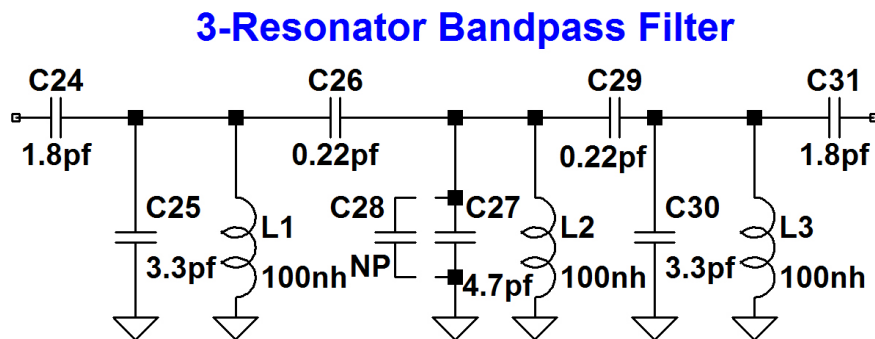

Figure A2- Schematic of Main Bandpass Filter

W1GHZ

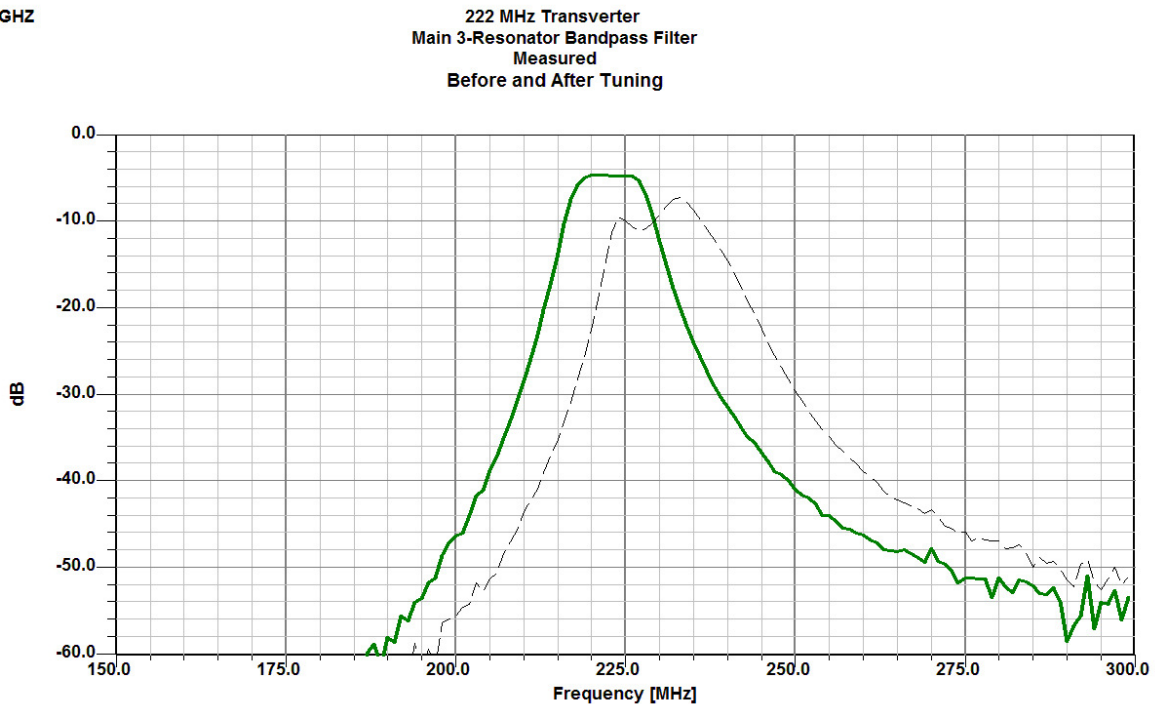

Figure A3 – Response of Main Bandpass Filter

The next filter in the transmit chain is the interstage TX Bandpass Filter between A6 and A5. This is a two-section bandpass filter using the same tunable Coilcraft inductors in shield cans. The schematic is Figure A3, and the response is in Figure A4. This filter also only took a bit of tuning, yielding a response broad enough to cover the whole band.

2-Resonator TX Interstage Filter

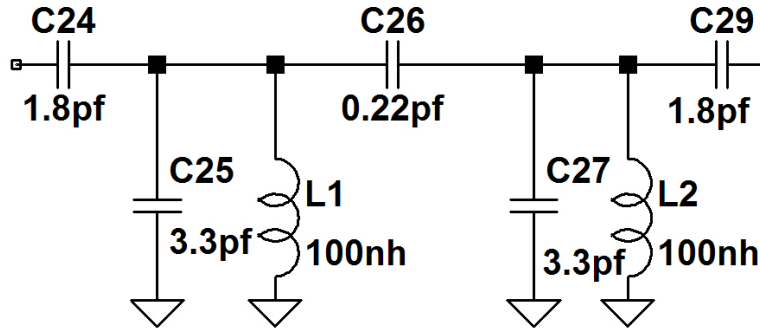

Figure A4 – Schematic Diagram of Two-resonator TX Interstage Filter

W1GHZ

222 MHz Transverter
TX Interstage 2-Resonator Filter
Measured
Before and after Tuning

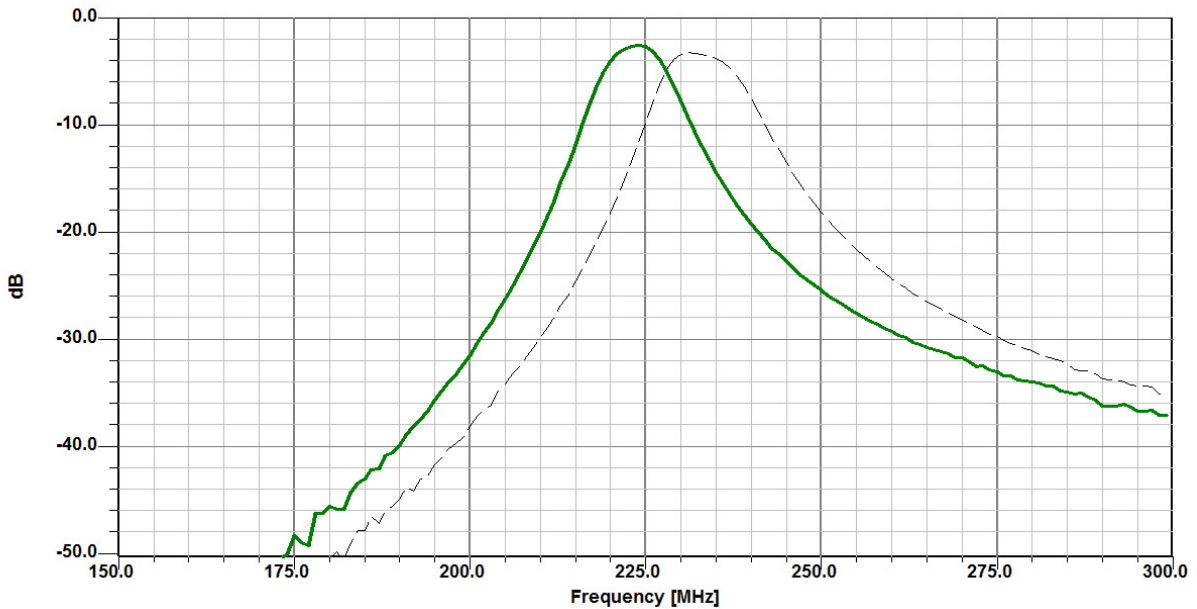

Figure A5 – Response of Two-resonator TX Interstage Filter

At the transmit output a low-pass filter reduces harmonic output. This is a simple π network with two SMT capacitors and an SMT inductor, shown schematically in Figure A5. The simple filter is optimized for VSWR at 222 MHz and provides modest harmonic reduction, as shown in Figure A6. The design value for the capacitors is 18 pf, but the PCB layout includes large pads which add enough capacitance so that the chip capacitors had to be reduced to 15 pf.

TX Lowpass Filter

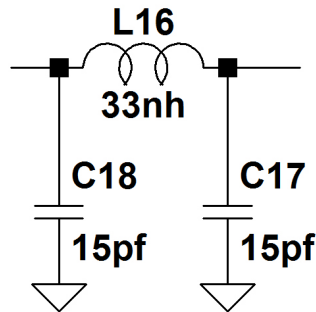

Figure A6 – Schematic of Transmit Output Low-pass Filter

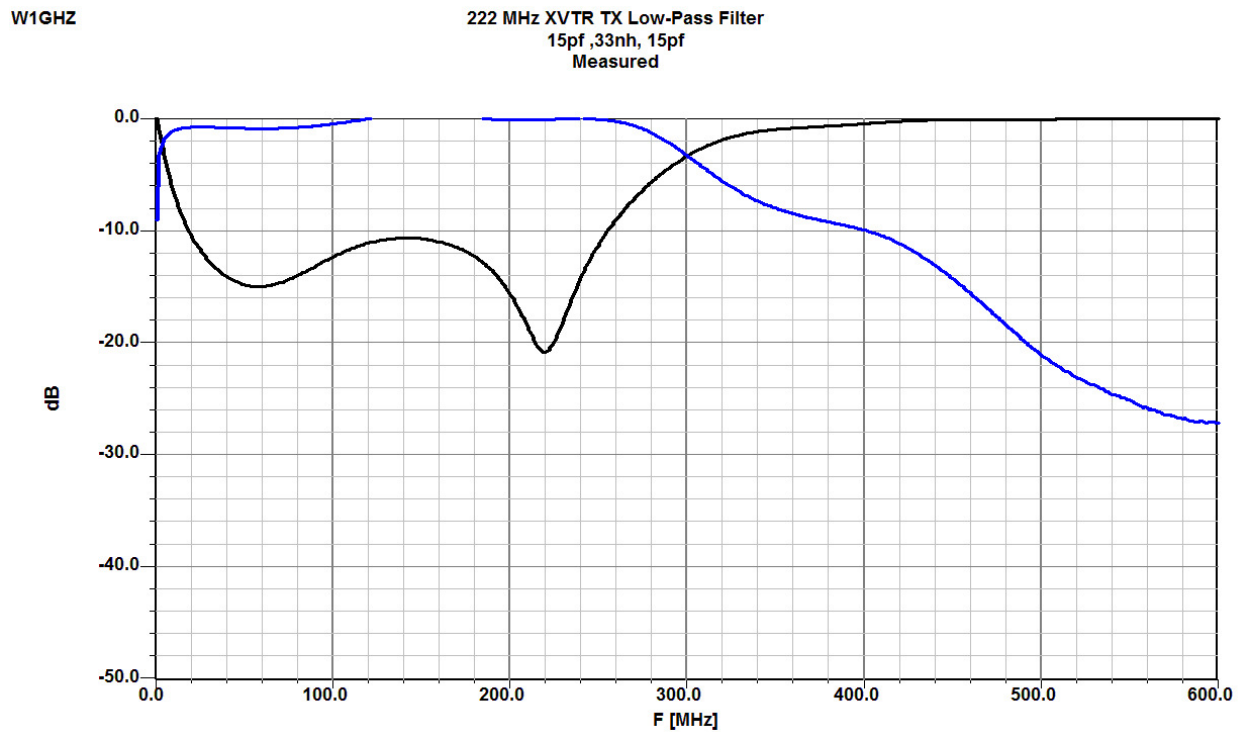

Figure A7 – Response of Transmit Output Low-pass Filter

The receiver input network from the antenna, with the schematic in Figure A7, is a very broad low-pass filter, with response tuned to 222 MHz shown in Figure A8. The inductor is a tunable Coilcraft inductor like the transmit filters, but without the shield can. This filter is tuned for best noise figure after final assembly.

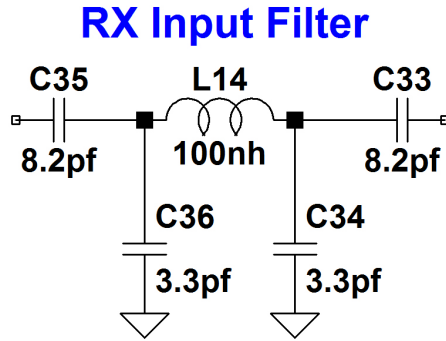

Figure A8 – Schematic of RX Input Filter

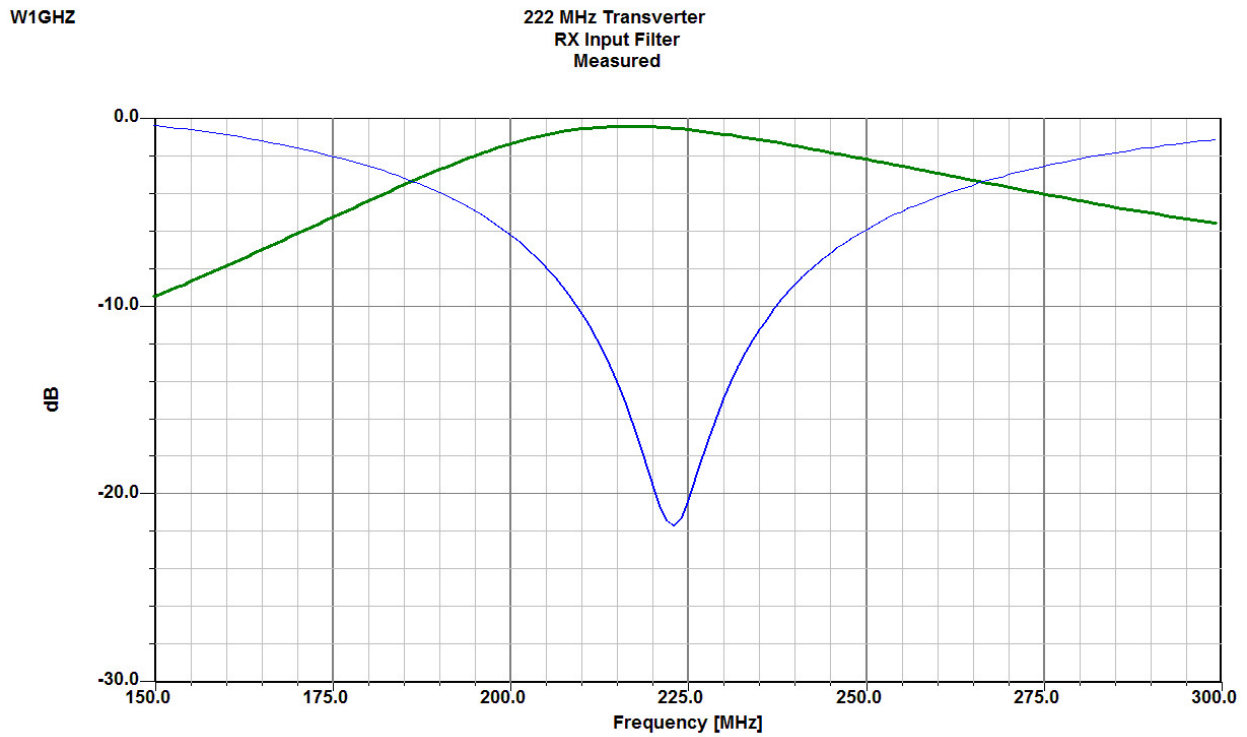

Figure A9 – Response of RX Input Filter

On the IF side, both transmit and receive IF amplifiers are followed by broad bandpass filters centered at 28 MHz using SMT capacitors and inductors. The RX and TX IF filter schematics are shown in Figures A9 and A10 respectively, and the response is shown in Figure A11 for RX and A12 for TX.

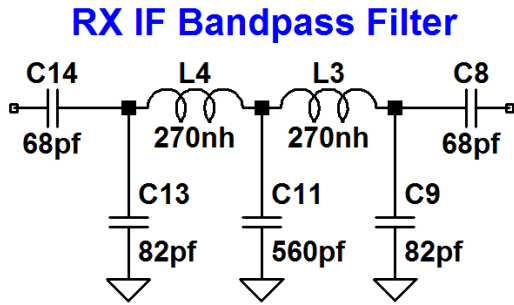

Figure A9

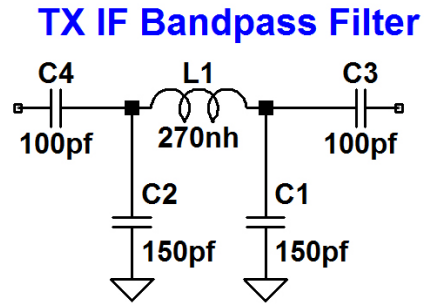

Figure A10

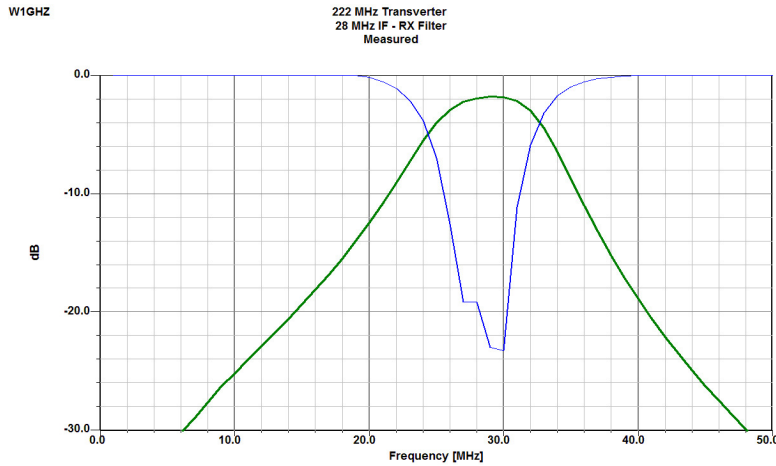

Figure A11 – Response of RX IF Bandpass Filter

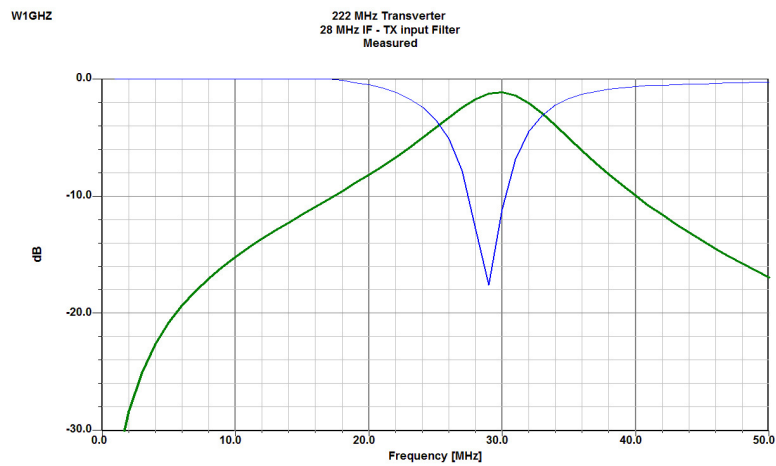

Figure A12 – Response of TX IF Input Filter