

Phase Noise...

How much is too much?

Presented at Microwave Update 2009

Brian Justin, WA1ZMS

An answer is...

-72dBc/Hz @ 1kHz

(threshold of noisy signal)

or

-48dBc/Hz @ 1kHz

(2dB loss in RX minimum discernable signal)

But just where did those numbers come from?

How much phase noise?

- Subjects covered in this talk will be:
 - What is phase noise?
 - Types or classes of noise. (i.e.: near vs. far)
 - Why care about phase noise?
 - Some practical measured data and signal recordings.

What is Phase Noise?

- Phase noise is ‘random’ noise energy near an RF carrier such as a local oscillator signal. Phase noise is measured in dBc/Hz at a given frequency offset.
- As the carrier frequency is increased through the LO chain, the phase noise is scaled by:

$$20\text{Log}(n), \text{ where } n = \text{ratio of frequencies}$$

- For example, a 10MHz signal with phase noise of -105dBc/Hz @ 1KHz would be the ‘same’ as a 1150MHz signal with -63.8dBc/Hz @ 1KHz phase noise.
- For amateur radio purposes, phase noise can be classified as either “*Near*” or “*Far*”.

What is Phase Noise?

- *Near* phase noise affects how the signal sounds to the operator. i.e.: raspy, dirty, aurora like
- *Far* phase noise limits the dynamic range of the receiver and also includes the broadband noise that a transmitter creates.
- For this presentation, only *White PM* noise is considered *Far* noise.
- All others can be considered as *Near* noise.

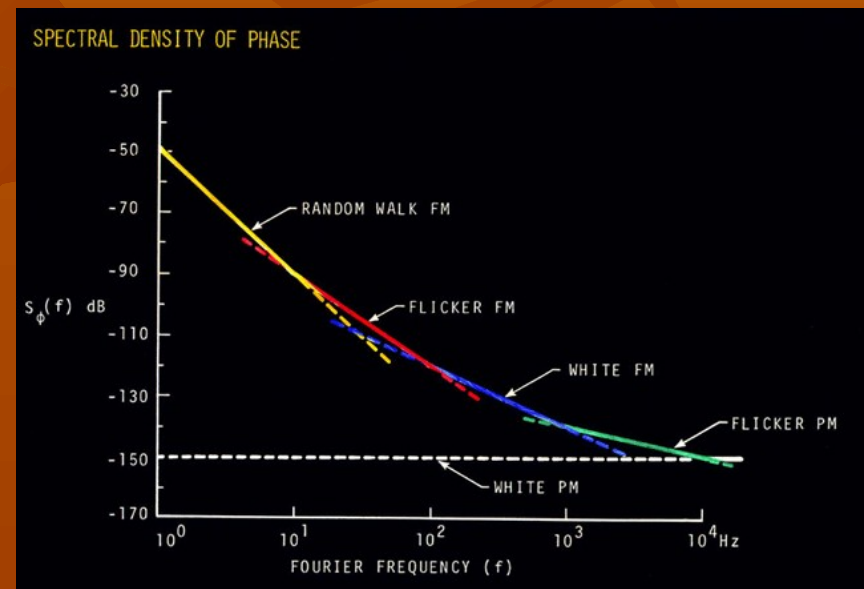

Why care about Phase Noise?

- *Far* phase noise limits dynamic range and impacts others on crowded bands.
- For bands above 10GHz, *near* phase noise can impact DX, while *far* noise is less important.
- *Near* phase noise limits narrow-band modulation techniques. i.e.: WSJT, PSK31, QRSS, etc.

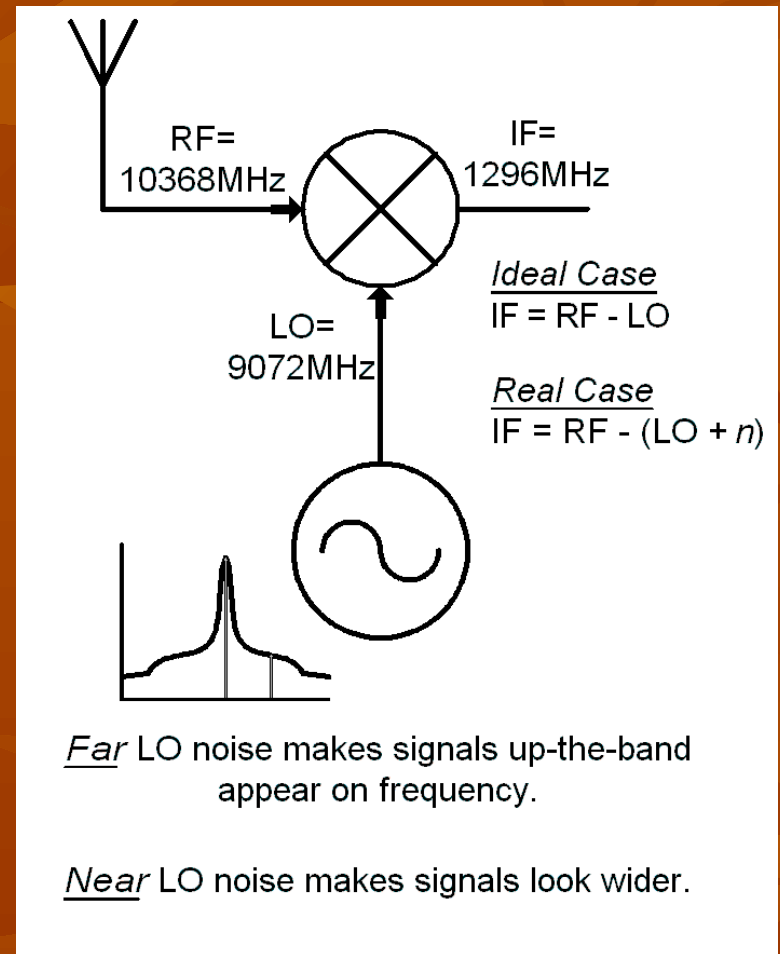

Think Frequency Stability

- *Stability* is a measure of steadiness. Think short-term. How close to 10368.1000 MHz can you maintain from moment-to-moment?
- A tool used to measure *stability* can be a phase noise test system. But you'll need to do some math to convert from the frequency domain to the time domain.
- Stability determines what a signal sounds like.

Frequency Reference Comparison

| | FRS Rubidium | Efratom FE-5650 | Corning OCXO | Cesium | HP 10811 | H-MASER | Wenzel OCXO |
|-------|--------------|-----------------|--------------|------------|------------|------------|-------------|
| 1Hz | -65dBc/Hz | Not spec'd | -80dBc/Hz | -100dBc/Hz | -103dBc/Hz | -104dBc/Hz | -114dBc/Hz |
| 10Hz | -100dBc/Hz | -100dBc/Hz | -120dBc/Hz | -130dBc/Hz | -133dBc/Hz | -129dBc/Hz | -144dBc/Hz |
| 100Hz | -110dBc/Hz | -125dBc/Hz | -140dBc/Hz | -135dBc/Hz | -153dBc/Hz | -146dBc/Hz | -162dBc/Hz |
| 1KHz | -125dBc/Hz | -145dBc/Hz | -145dBc/Hz | -140dBc/Hz | -162dBc/Hz | -152dBc/Hz | -168dBc/Hz |
| 10KHz | Not spec'd | Not spec'd | -150dBc/Hz | -145dBc/Hz | -162dBc/Hz | -154dBc/Hz | Not spec'd |

Phase Noise of Various Lab-Grade References

- These are typical best-in-class numbers.
- If you use a different LO reference or other free-running XO, you could be giving up MDS performance

Methods of Frequency Generation

- Direct multiplication
 - Simple, needs filtering, $1/f$ noise, follows $20\text{Log}(n)$
- Phase locked loops
 - Helpful if value of N is high, loop BW limitations, phase/frequency detector issues
 - Frequency West is good example
- Direct synthesis
 - Single frequency at-a-time solution, need good filtering
 - Can take advantage of good near and far noise of OCXO
 - Very simple in concept, relies Direct Multiplication

Noise can be tough to define.

- Not all noise is flat with frequency.
- Noise can be FM (PM) or AM.
- FM noise is “easy” to replicate.
- AM noise not so easy, because...
- There can also be AM to PM conversion!

- PLL noise is different inside & outside loop bandwidth.

PLL Noise Result...

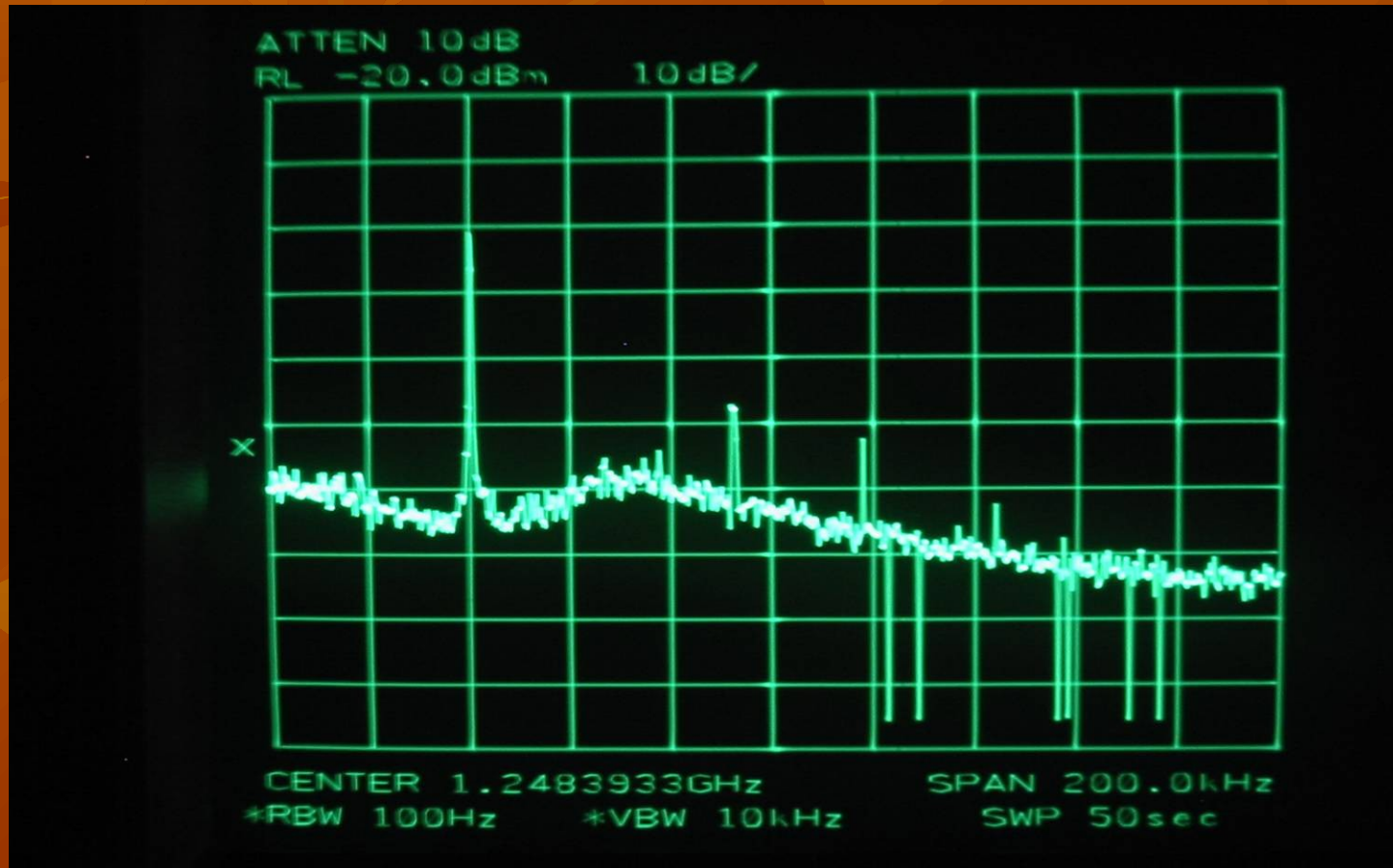

A simple proposed test system...

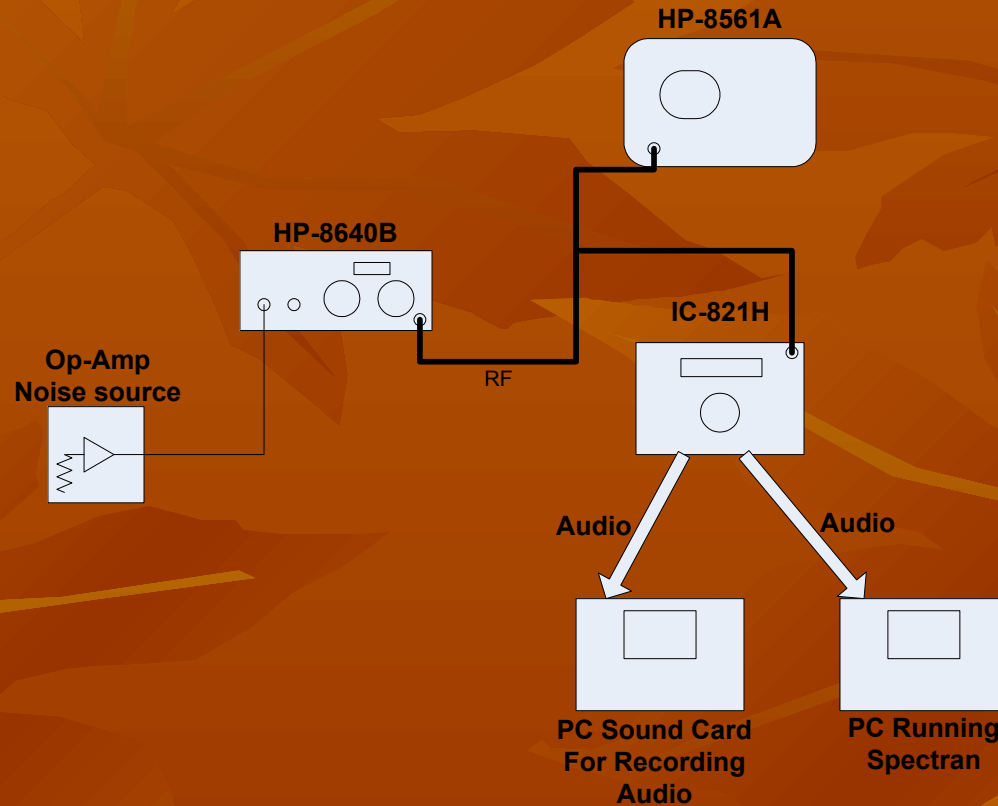

Let's make some noise

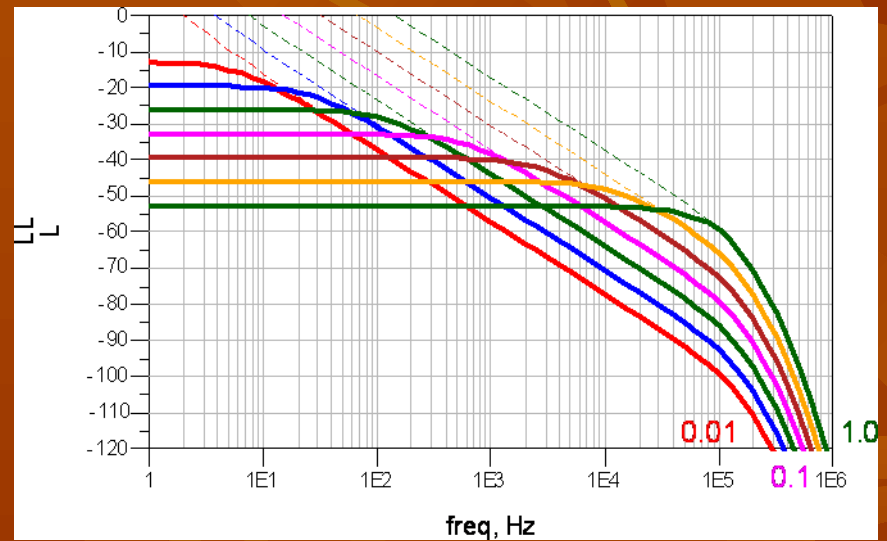
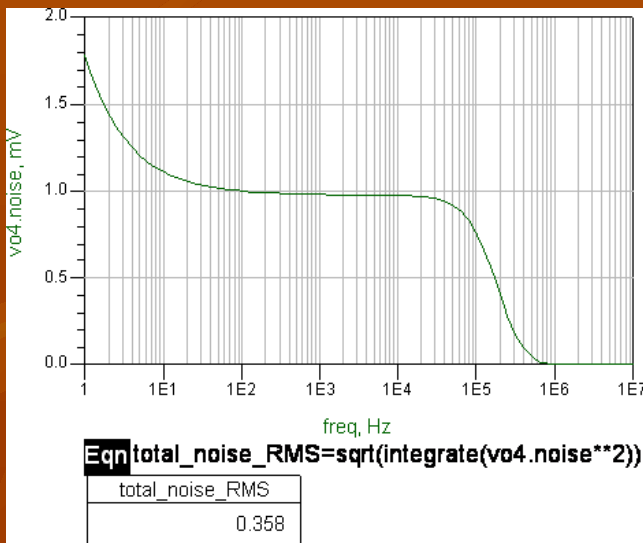
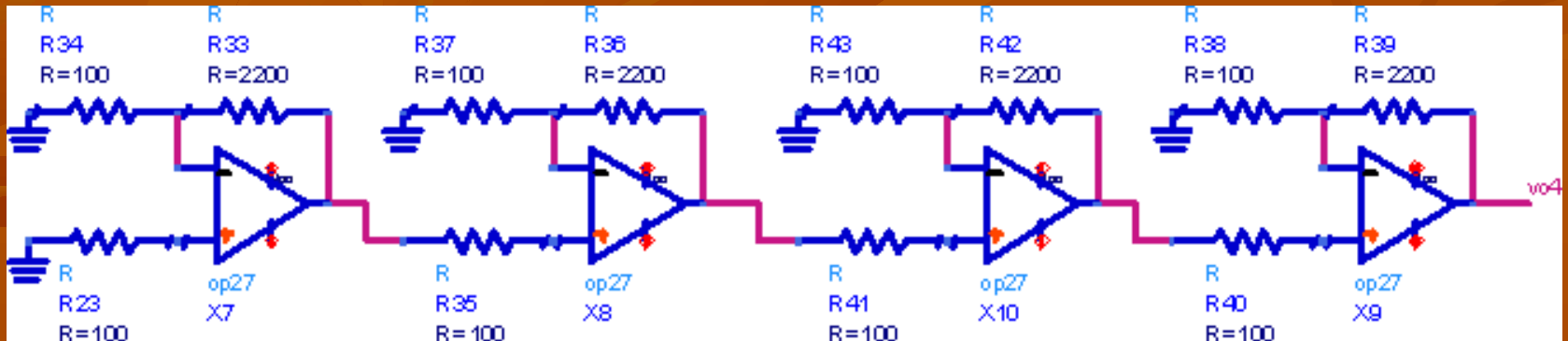

Now we modulate a signal with noise

- Decided to run tests at VHF for simplicity.
- I hope someone can duplicate these tests for verification.
- Best VHF sig gen for noise at “château ZMS” is HP-8640B.
- Set sig gen for high modulation BW & sensitivity. (i.e.: 100KHz deviation for 1V)

Now we modulate a signal with noise

- Set sig gen for -10dBm and feed output to both HP-8561A spectrum analyzer & Icom IC-821 2m rig.
- 2m RX set for ~144.200MHz, USB and stock IF filter (filter spec: 2.3kHz/-6dB & 4.2kHz/-60dB)
- Plot and record carrier with no added noise
- Increase noise input until signal just starts to “sound bad” < - **VERY SUBJECTIVE!**
- Keep increasing noise and plot & record results
- Logged 5 data sets...

Measured spectral plots

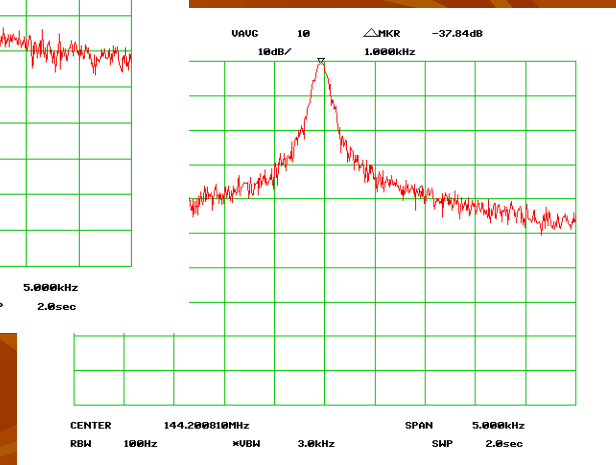
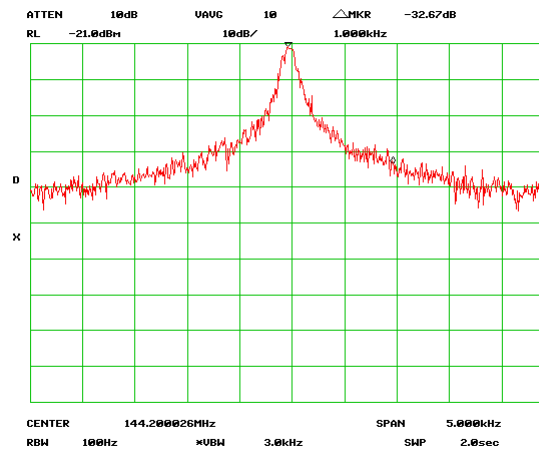
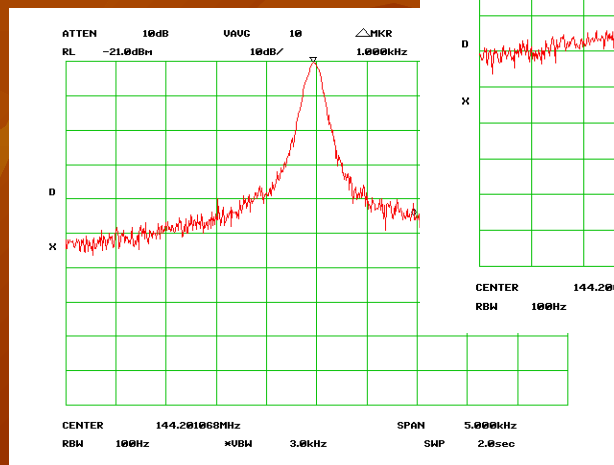
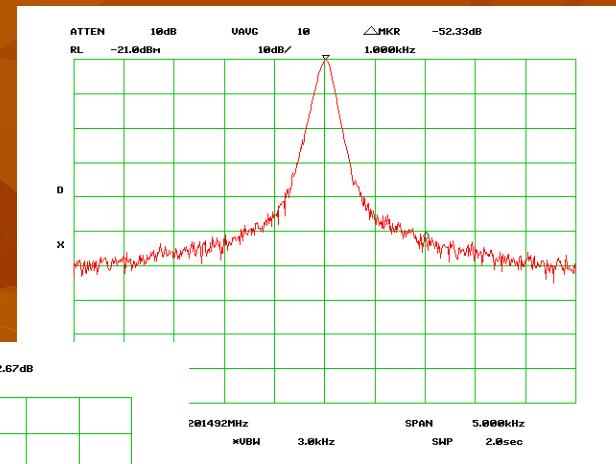
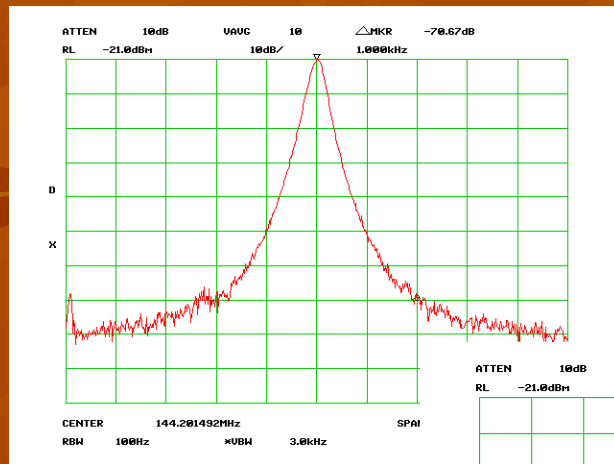

Add noise...

Free running HP-8640B on 144.200 +/- MHz with FM noise modulation
Noise @ 1kHz is -72.33dBc/Hz (18dB worse than baseline)

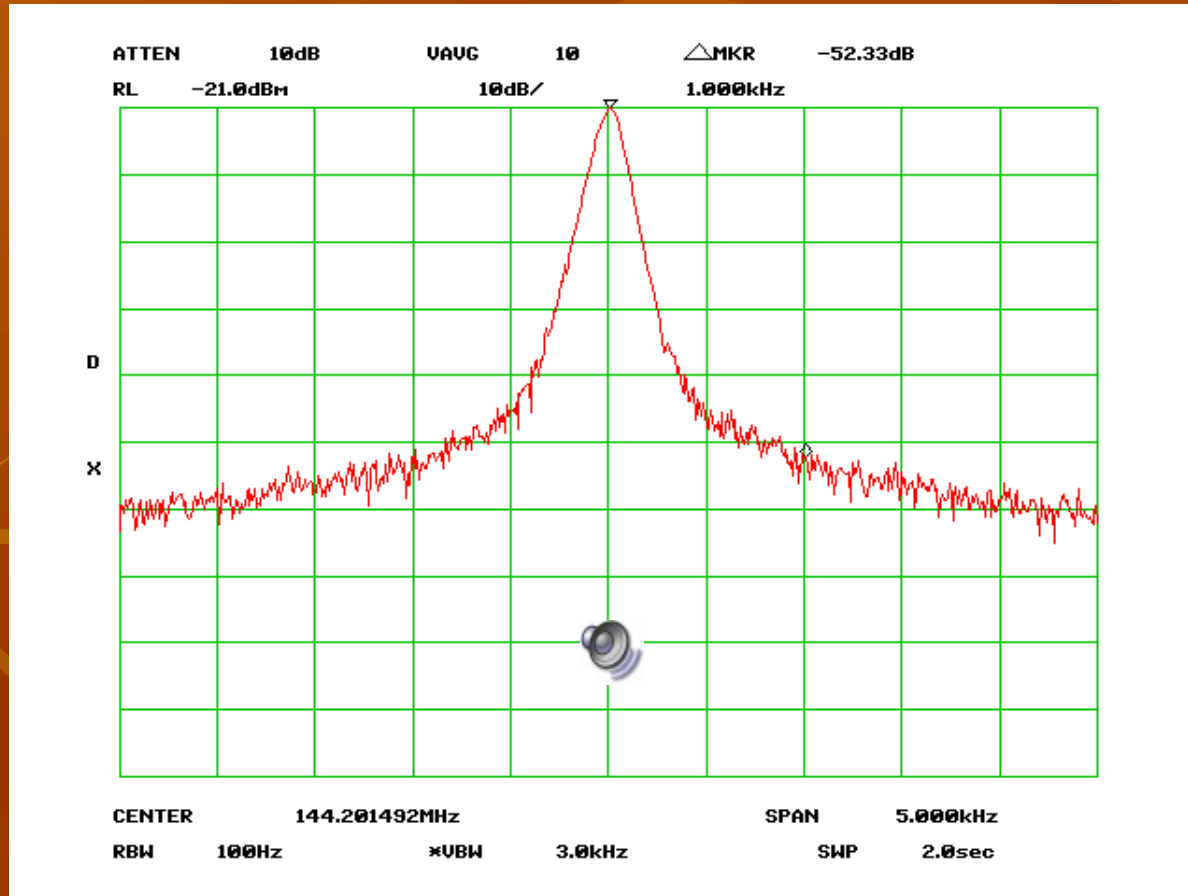

Add more noise...

Free running HP-8640B on 144.200 +/- MHz with FM noise modulation
Noise @ 1kHz is $-64.66\text{dBc}/\text{Hz}$ (26dB worse than baseline)

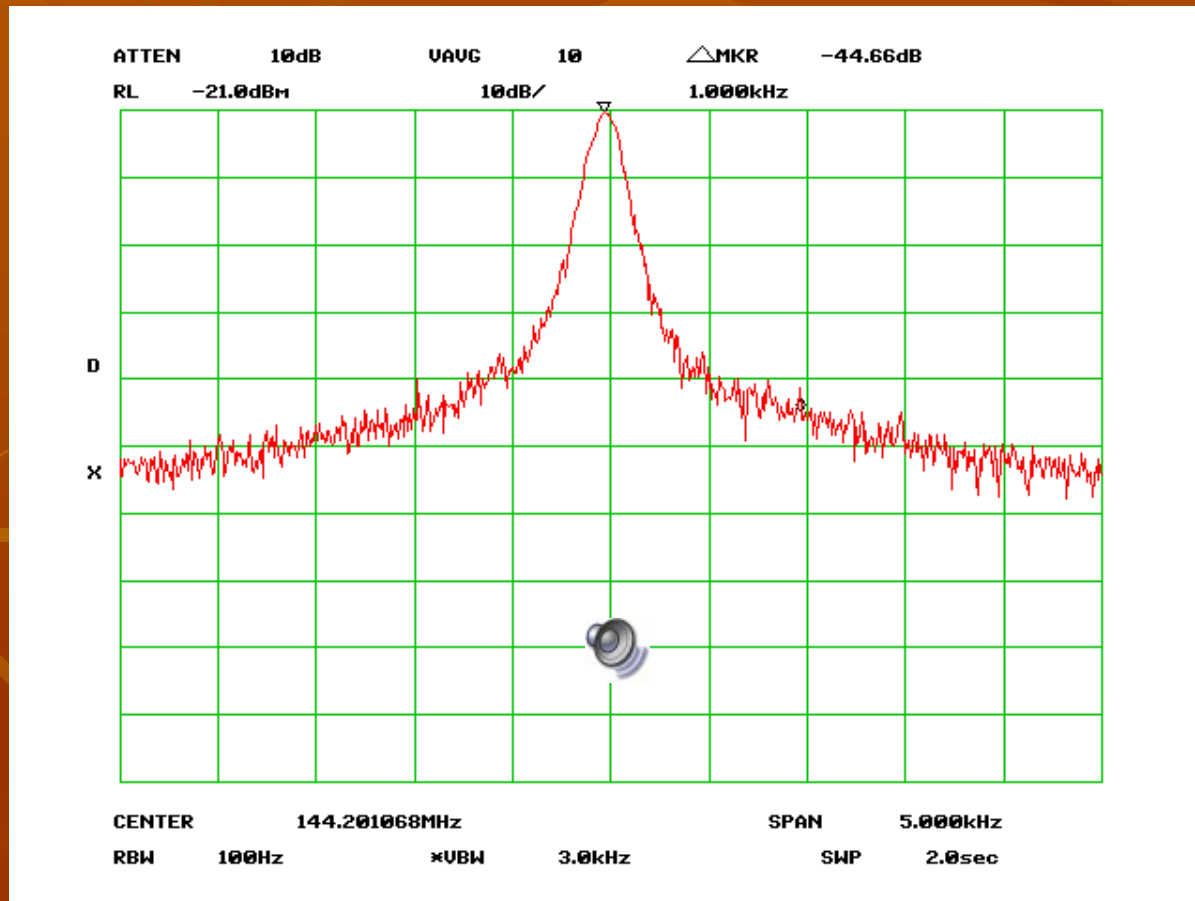

Add *even more* noise...

Free running HP-8640B on 144.200 +/- MHz with FM noise modulation
Noise @ 1kHz is -57.84dBc/Hz (32dB worse than baseline)

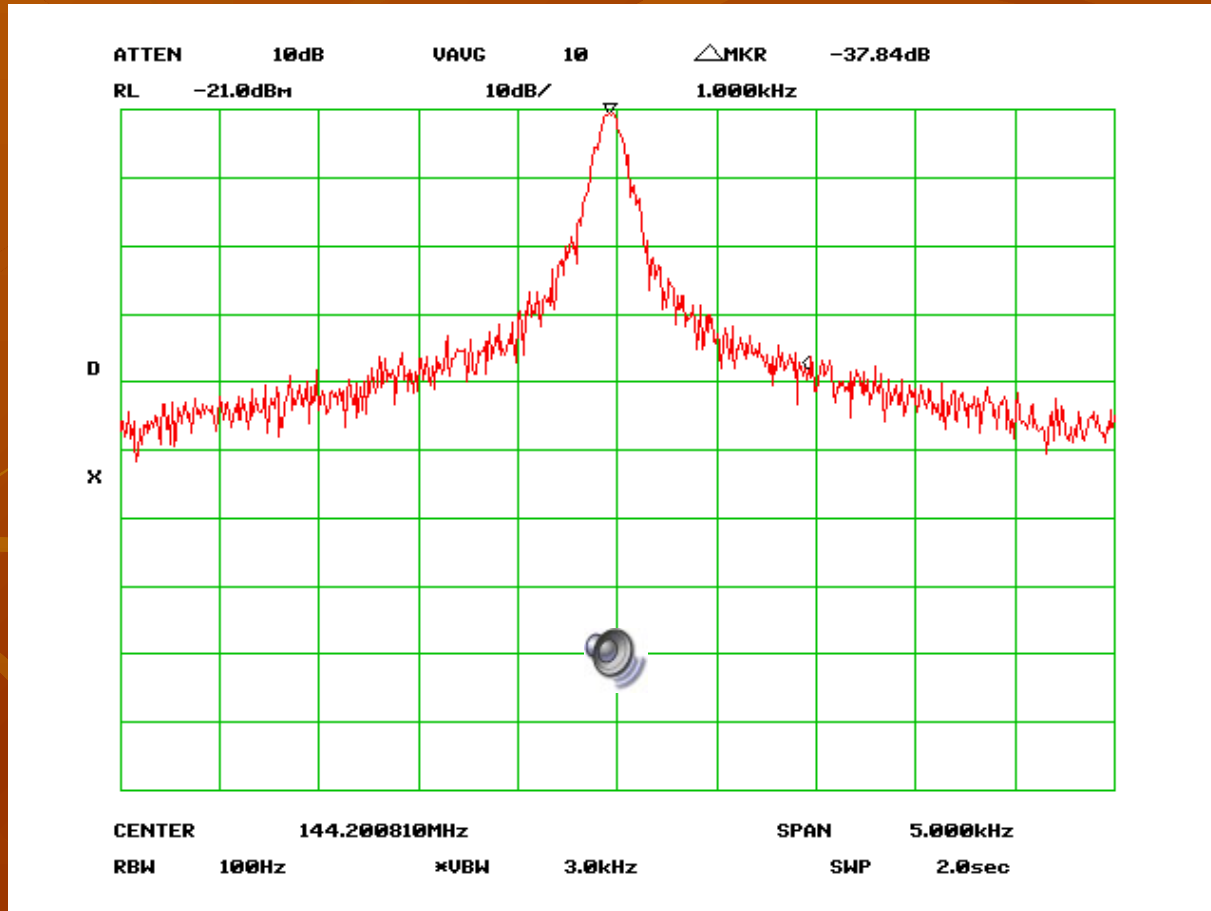

More and more noise...

Free running HP-8640B on 144.200 +/- MHz with FM noise modulation
Noise @ 1kHz is -52.67dBc/Hz (38dB worse than baseline)

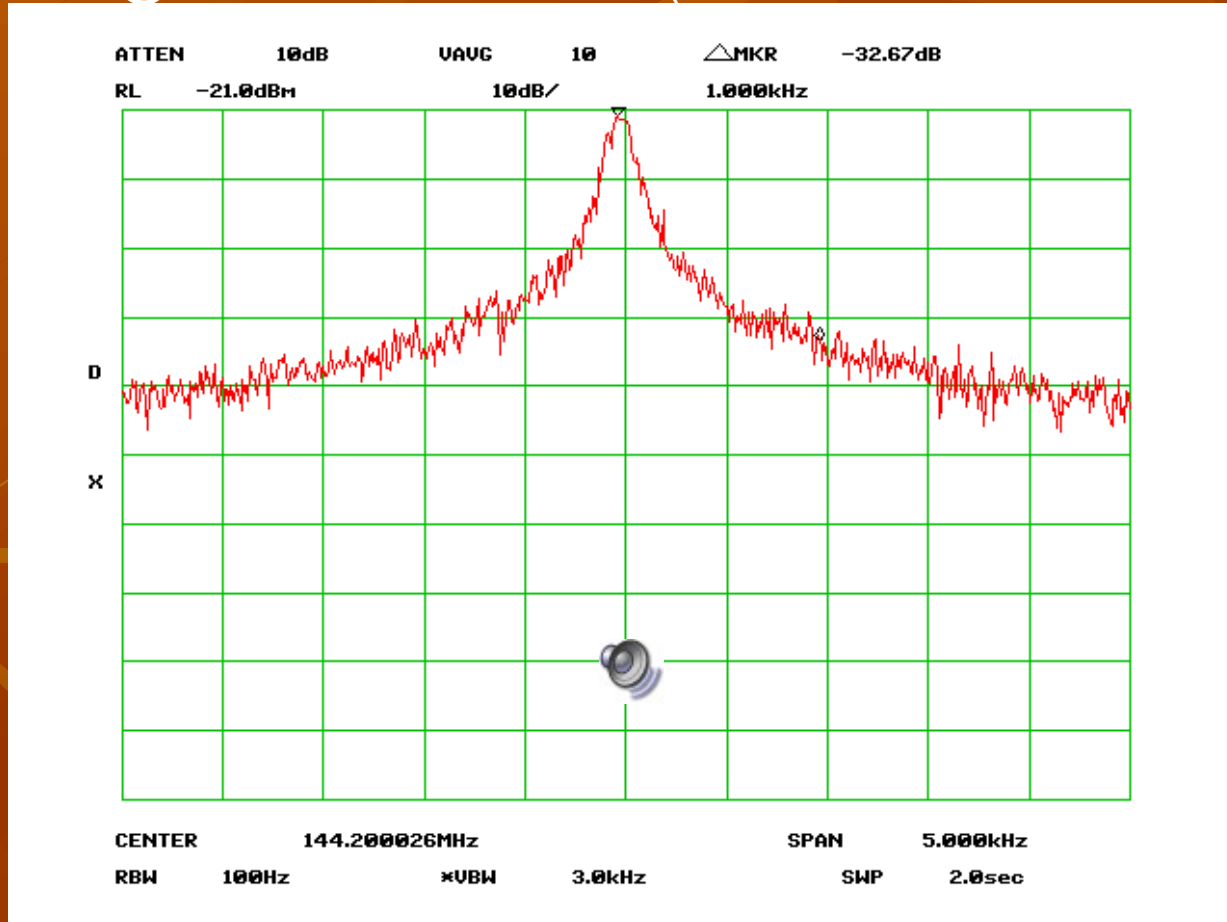

What about MDS tests?

- Set a very weak, but “clean” signal. Call that your MDS level.
- Raise RF level by say 2dB.
- Now add noise until signal has degraded back to MDS level.
- What’s the PN now?

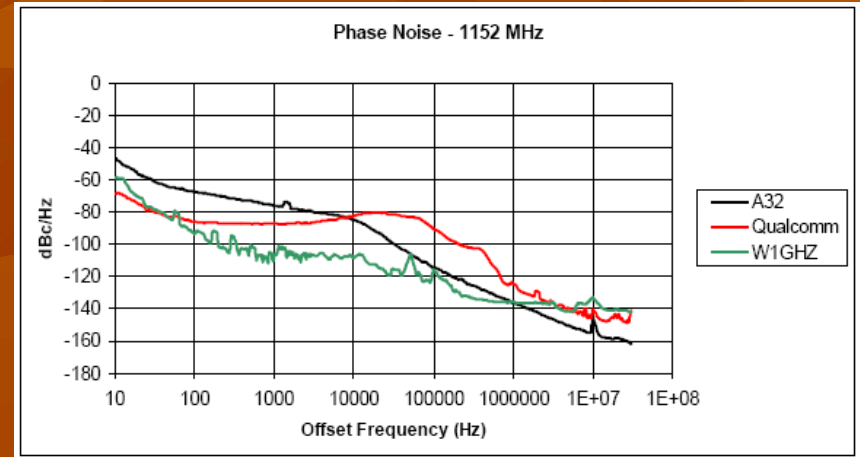

W1GHZ's PN plots when he experienced a 2dB “hit” in MDS between BLK & GRN curves on plot.

From NEWS Newsletter/W1GHZ/WA1VUG

Baseline the MDS...

Free running HP-8640B on 144.200 +/- MHz

Noise @ 1kHz is -90.67dBc

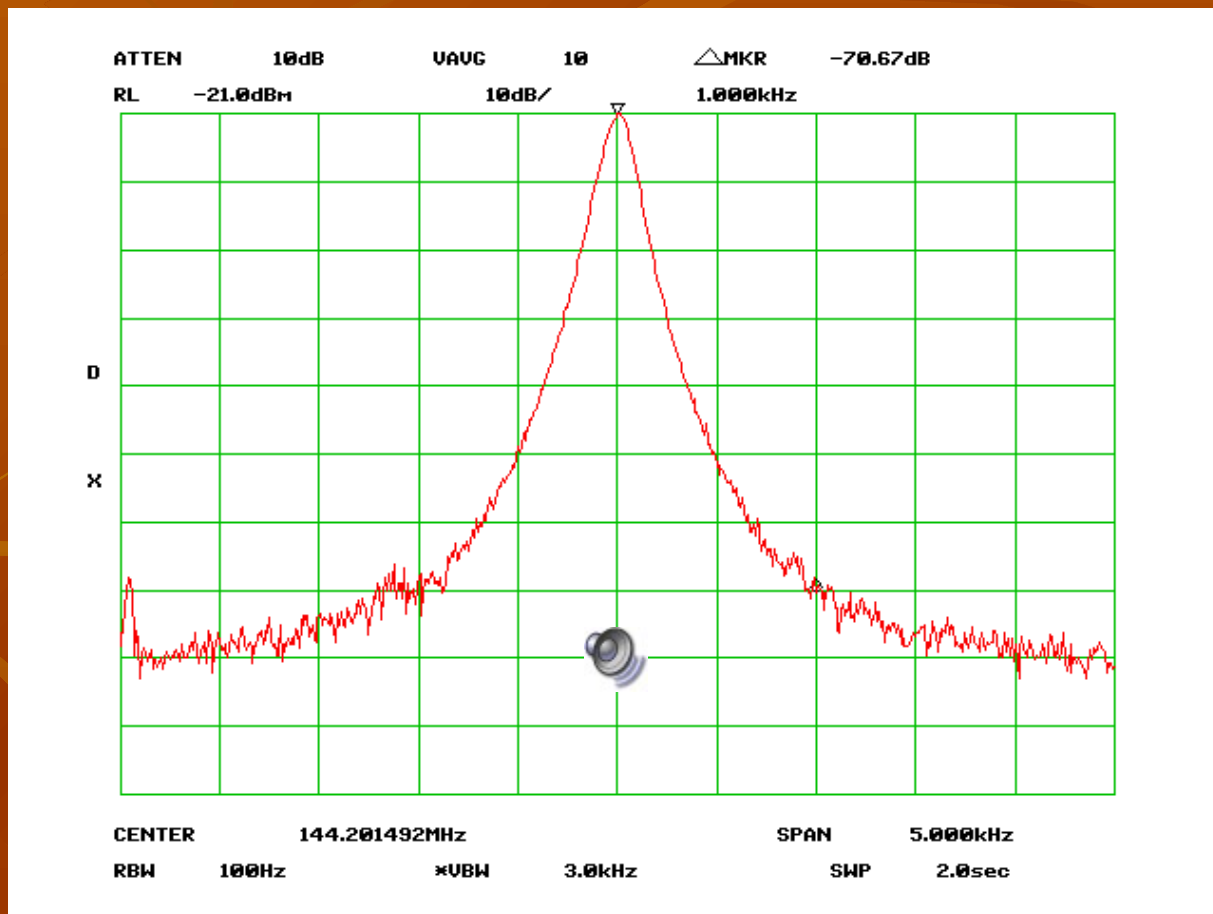

2dB more signal, but noise also to get to the same MDS

Free running HP-8640B on 144.200 +/- MHz
Noise @ 1kHz is -46dBc!!!!

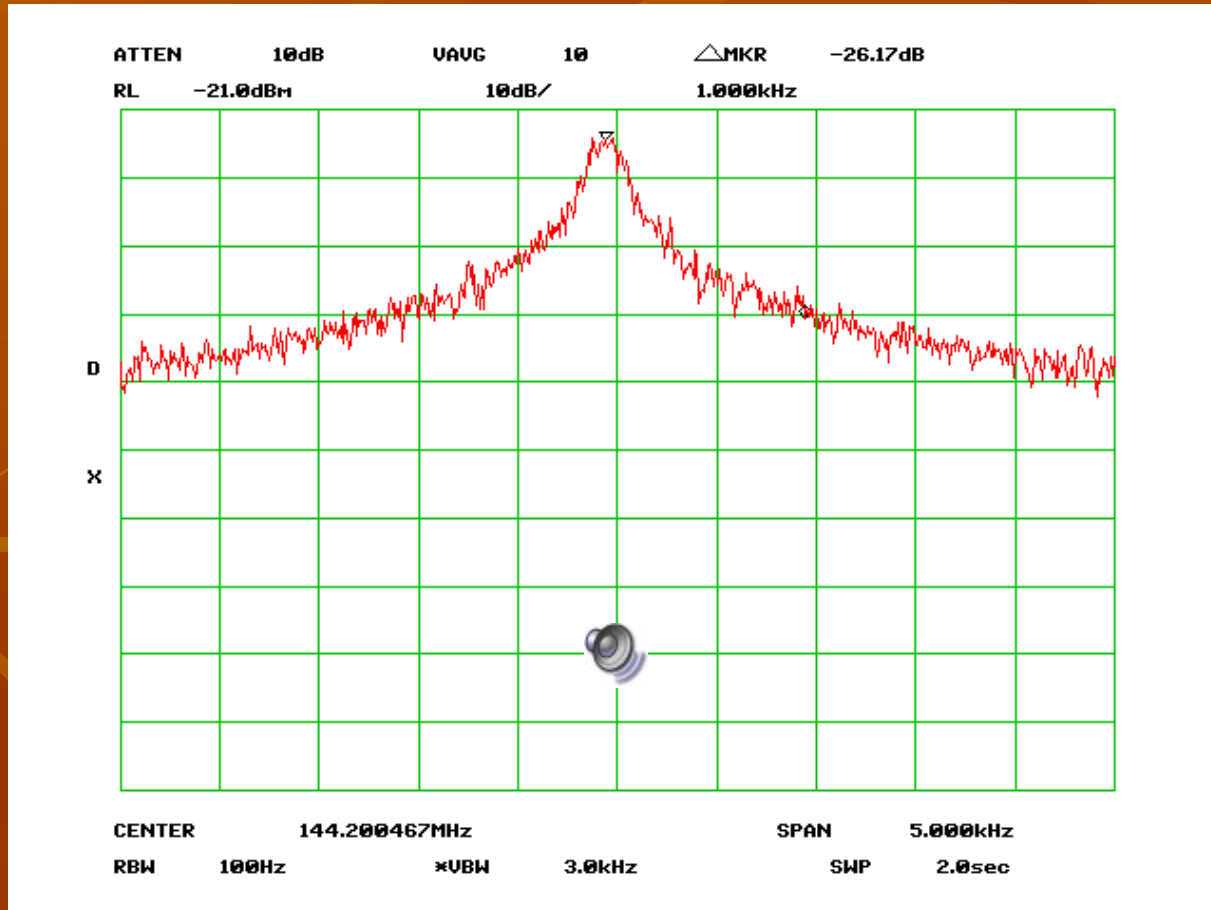

So what can we conclude?

- The 'ZMS MDS test shows PN can be as bad as $-46\text{dBc/Hz @ } 1\text{kHz}$ and only give up 2dB of RF performance.
- The 'GHZ data shows $-75\text{dBc/Hz @ } 1\text{kHz}$ but his test was at 1152MHz and needs to be scaled by about 18dB to represent the noise of his resulting 10GHz MDS signal tests.
- Rescaled, the 'GHZ result is around $-57\text{dBc/Hz @ } 1\text{kHz}$.

So multiple answers?

- If you want NO phase noise degradation of your signal, aim for -72dBc/Hz @ 1kHz.
- If you have rather flat noise with frequency, then maybe -48dBc/Hz @ 1kHz is worth 2dB.
- If you have a PLL like the A32 module whose noise is not flat, then maybe -57dBc/Hz @ 1kHz is worth 2dB.

So multiple answers?

- The real bottom line is that noise shape and the choice of mode/IF filter BW has significant influence on what noise level is tolerable.
- All the above was for CW, each digital mode will have a unique threshold for noise as well as C/N for a given BER.

Final thoughts...

- This is/was just a start!
- It's now up to the rest to take the test methods one step farther and either plot a matrix of MDS vs. PN shape, or include digital modes.
- As for me, I'll aim for -72dBc/Hz @ 1kHz and try for the best sounding signal I can have.
- But if it's for a new grid on the mm-wave bands, then anything goes!

Thanks...

- Bill Overstreet, K4AJ for help with noise simulations
- Paul Wade, W1GHZ for his MDS data